



University of Genova

YACHT DESIGN MASTER DEGREE

GRADUATION THESIS

Design of a 24-meter motor yacht

This thesis is submitted in partial fulfilment of the requirements for the degree of Master of Engineering in Yacht design

Professor

MARCO FERRANDO

Student

MOHAMMAD ABDUR RAIHAN

S4977722

March 2024

Abstract

The objective of this thesis is to carry out the design of a 24-meter motor yacht, along with developing a yacht design and verifying in several steps to satisfy the operational safety and construction requirements and sustainability. In recent years the most popular sizes of modern yachts range between 20 meters to 28 meters. The philosophy behind this range controlling market behaviour in line with new innovative propulsion design, low maintenance cost comparatively short construction period, economical sustainability, and lower SOLAS requirement.

A full displacement hull has been selected for our boat to gain more extensive liveable space and improve operation facility. An integrated propulsion system has been introduced rather than a conventional shaft system to make the engine room space more workable for the crew.

Hull material has been designed for aluminium construction and lightship has been calculated at 130T considering all interior, piping, types of machinery, and electrical equipment. The arrangement has been divided into five different zones to calculate LCG, VCG, and TCG accurately. In stability calculation, hydrostatic properties have been generated using 3d modelling software GHS to get the righting lever and finally, the GZ curves have been drawn for three different loading conditions to satisfy the Intact stability criteria. Structural scantlings are calculated based on RINA class rules with adequate factors of safety. For resistance and power prediction Maxsurf software has been used to find the hull resistance and the corresponding minimum required effective power for the motor has been iterated. Finally, IPS 600 series engine model has been selected with an adequate overall propulsive coefficient (OPC) and propeller shaft power have been decided with a cruising speed of 11.5 knots.

Keywords: Displacement, Stability, Resistance, Structural Scantling, Propulsion power and Nautical miles, OPC

List of words

GHS -	General Hydrostatic Software use for yacht stability calculation
MAXSURF –	A Naval Architectural software that provides integrated tools for hull modelling Stability, motion, and resistance prediction
LCG	Longitudinal Centre of Gravity
KN	Horizontal distance between Center of Gravity and Center of Buoyancy
VCG	Vertical Center of Gravity of yacht
TCG	Transverse Center of Gravity of yacht
Displacement	Total weight of ship includes lightweight and deadweight.
Lightship	All weights of ships structural, all construction materials which are fixed Excluding consumables, fuel, fresh water, Lube oil etc which are not fixed And varies during voyage.
IPS 600	An inboard performance system with engine, gearbox and propeller azipod propulsion system manufactured by VOLVO PENTA
GZ	Righting arm drawn against different heeling angle for stability criteria
LCF	Longitudinal Center of Floatation
LCB	Longitudinal Center of Buoyancy
KM ^T	Vertical Metacentric distance from keel
KM _L	Longitudinal metacentric distance from keel

Table of Contents

1. Introduction	1
2. Market Analysis	2
2.1 Observation on Market analysis	8
3. Characteristic of yacht	9
4. Displacement	10
4.1 Market Analysis on Displacement	10
4.1.1 Displacement summary from Market analysis	11
4.2 Detail Displacement Calculation	12
4.2.1 Summary of Lightship	21
4.2.2 Voyage, Mid voyage, and Arrival Condition	22
4.3 Displacement using Software	23
5. Stability Check	24
5.1 Cross Curves results for even keel condition (no trim)	24
5.2 Hydrostatic Properties	26
5.2.1 Hydrostatic Curves	28
5.3 KN Values in voyage, mid-voyage and arrival condition	29
5.3.1 Summary of KN Values	30
5.3.2 Tanks dimension for free surface correction	31
5.4 GZ curves for three conditions	37
5.4.1 Area under GZ Curve and Intact Stability Criteria	39
6. Structural Scantlings	39
6.1 Scantling Calculation	39
6.1.1 Displacement Yacht	39
6.1.2 Block Coefficient	39
6.1.3 Acceleration	40
6.1.4 Design pressure bottom plate and side shell	40
6.1.5 Material Factor	40
6.1.6 Minimum Thickness requirement for plates	40
6.1.7 Primary supporting members	41
6.1.8 Section Modulus Primary member	41

6.1.9	Keel Plate Length and Thickness	41
6.1.10	Bottom Side Girder	41
6.1.11	Bottom Longitudinals	42
6.1.12	Side Transverse Frame.....	42
6.1.13	Side Longitudinal.....	43
6.1.14	Deck Longitudinal.....	43
6.2	Summary of Structural Scantling	44
7.	Drawings.....	44
8.	Resistance and Power Prediction.....	49
8.1	Holtrop effective power Calculation	53
8.2	Engine model and propeller shaft power	53
8.2.1	Inboard performance system IPS 600 series	54
8.3	Fuel consumption and cruising distance	55
9.	Bilge and Fire fighting system	57
9.1	Fire Fighting System	57
9.2	Bilge System	57
9.3	Bilge system schematic drawing.....	57
10.	Conclusion.....	59

List of Figures

Figure 1. OKAN 80 FLY	2
Figure 2. BERING B70.....	2
Figure 3. MAGNOLIA.....	2
Figure 4. OKAN 80 FLY – Exterior	3
Figure 5. BERING B70 Yacht -Exterior.....	3
Figure 6. MAGNOLIA -Exterior.....	3
Figure 7. OKAN 80 FLY - Interior	4
Figure 8. BERING B70 - Interior.....	4
Figure 9. MAGNOLIA - Interior	4
Figure 10. OKAN 80 FLY – General Arrangement.....	5
Figure 11. BERING B70 - General Arrangement	5
Figure 12. MAGNOLIA - General Arrangement	6
Figure 13. Market Analysis – Exterior Aspect	6
Figure 14. Market Analysis – Interior aspect.....	7
Figure 15. Comparison of interior space	7
Figure 16. Market Analysis – Operational functionality	8
Figure 17. Hydrostatic Curves.....	28
Figure 18. GZ Curve for 100% loading, Voyage	37
Figure 19. GZ Curve for 50% Loading, Mid voyage.....	38
Figure 20. GZ Curve for 10% Loading, Arrival	38
Figure 21. Actual Bottom centre girder Scantling.....	42
Figure 22. Actual Scantling calculation of Bottom Longitudinal.....	42
Figure 23. Actual Scantling Calculation of side transverse Frame	42
Figure 24. Actual scantling of side longitudinal	43
Figure 25. Actual scantling of deck longitudinal.....	43
Figure 26: 3D hull model import to Maxsurf	49
Figure 27. Speed vs. Resistance curve.....	52
Figure 28. VOLVO PENTA IPS 600 series technical data.....	55
Figure 29. Fuel Consumption curve	55
Figure 30. Sea route from Geona to Malta 711 Nautical miles.....	56

List of Tables

Table 1. Weight calculation for each zone	13
Table 2. Summary of free surface correction	32
Table 3. GZ Calculation Condition 1	33
Table 4. GZ Calculation Condition 2	34
Table 5. GZ Calculation Condition 3	35
Table 6. Tangent of Trim angle	36
Table 7. Metacentric height	37
Table 8. Basic information on yacht and Maxsurf results for Resistance.....	50
Table 9: Maxsurf results with Holtrop resistance.....	51
Table 10. Holtrop effective power requirement for cruising speed.....	53

1.Introduction

A preliminary design project of a 24-meter motor yacht has been selected for this thesis. Developing from a very preliminary sketch to a complete General arrangement stage all methodology of design spiral have been properly followed. Primary sketch design has been modified progressively in order to comply all operational demands and standard rules requirements. Prior move into detail design, a primary market analysis has been carried out to understand the current market trends. Adequate information of current market demand and a comparative study of yachts played a vital role to introduce the latest optimized azipod propulsion technology, spacious owner cabin, panoramic view from upper deck as well as aluminium hull material selection makes her unique to compete in the market. Structural scantling, stability, interior arrangement, resistance, power prediction, modern liveable facilities, auxiliary system, fire control and safety have been analysed in this project yacht. In order to be unique and harmony in design a detail displacement calculation and intact stability criteria has been verified with class requirements. However, the length of yacht is 24-meter class rules has been implemented to calculate the main and branch bilge piping system. Finally, the yacht cruising speed and maximum speed has been declared 11.5 Knots and 12.5 Knots respectively.

Proposed sea route has been selected from Genoa to Malta.

2. Market Analysis

In market analysis similar characteristic of our project vessel have been analysed. Minimum three yachts have been selected and their detail interior, exterior, shape, displacement, ergonomics and hull construction materials and especially overall lengths have been analysed prior start our initial design concept of SERENE.

Figure 1. OKAN 80 FLY



OKEAN 80 FLY

- Builder –OKEAN, Brazil
- Semi displacement Hull
- Fiber glass/GRP
- L - 23.90m, B- 6.05m, d-1.76m
- Δ - 76t (Full)
- Cruising – 18 kn, Max – 25 kn
- Engine-1550 hpx2
- Fuel – 5745L, Fresh w –1690 L
- Cabin – 4, Service – 4+1+1,
- Crew -2+1

Figure 2. BERING B70



BERING B70

- Builder –Bering, Turkey
- Full displacement Hull, Steel +Aluminium
- L - 23.37m, B- 6.52m, d-1.33m,
- Δ - 98.7t (Full)
- Cruising – 8 kn, Max – 10 kn, Engine-305HPX2
- Fuel – 8200L, Fresh w – 1200L,
- Guest +crew – 6+2

Figure 3. MAGNOLIA



MAGNOLIA

- Builder – Turkish Yard, Turkey
- Displacement hull,
- Material- Wood
- L – 23.99m, B- 6.40m, d-1.60m,
- Displacement - 80 (Full)
- Cruising – 12 kn, Max – 14 kn,
- Engine- 600HPX2
- Fuel – 7000L, Fresh w – 2200L,
- Guest +crew – 8+2

Figure 4. OKAN 80 FLY – Exterior



- Fold-out balconies transform the interior/exterior.
- Expanding the livable space
- Lower aft deck swimming platform
- Economical fuel burn

Figure 5. BERING B70 Yacht -Exterior



- Relax sun bed on forward upper deck
- Tender boat placed on aft of bridge deck
- Flybridge fully open, upper deck forward vertical

Figure 6. MAGNOLIA -Exterior



- Bridge deck level extend up to the end
- Vertical shape of forward window
- External combination of wooden structure

Figure 7. OKAN 80 FLY - Interior

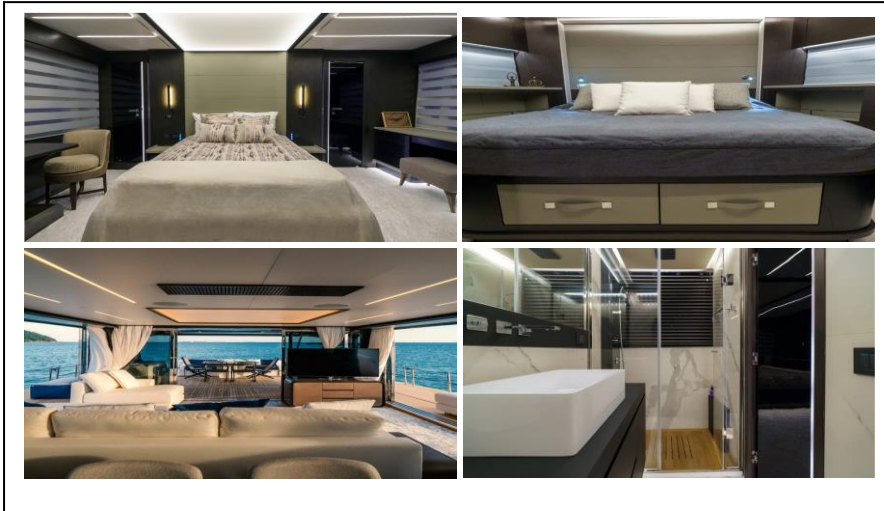

- Panoramic View
- Comfortness
- Spacious

Figure 8. BERING B70 - Interior



- Panoramic
- Economic Fuel burn
- Spacious Livable area

Figure 9. MAGNOLIA - Interior



- Spacious saloon area
- Ergonomics
- Variety in interior design

Figure 10. OKAN 80 FLY – General Arrangement

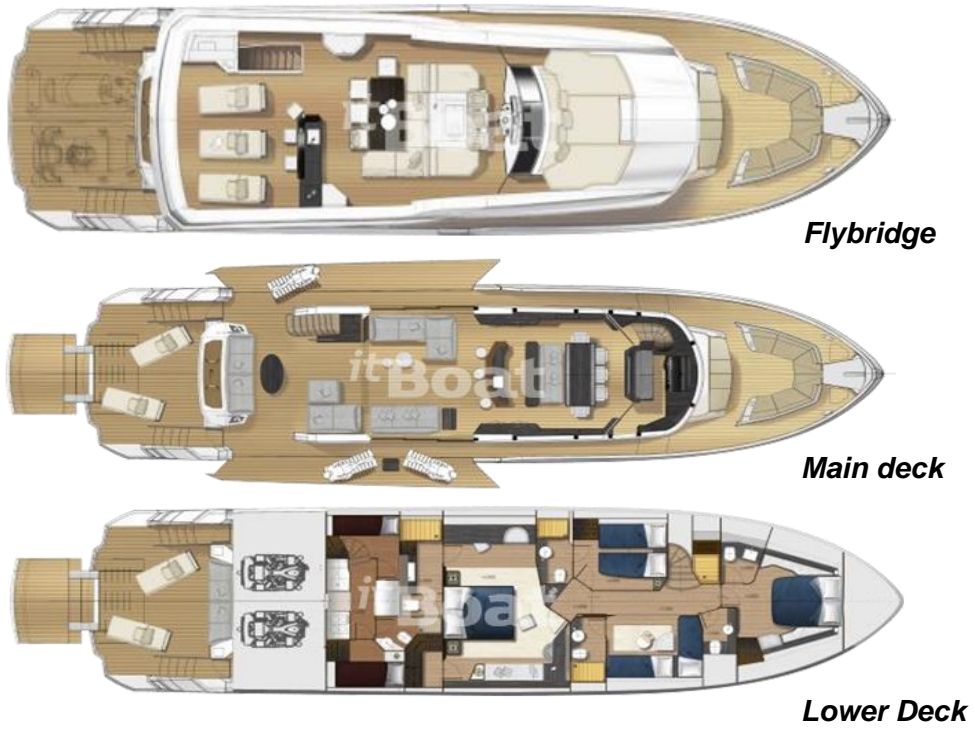

Figure 11. BERING B70 - General Arrangement

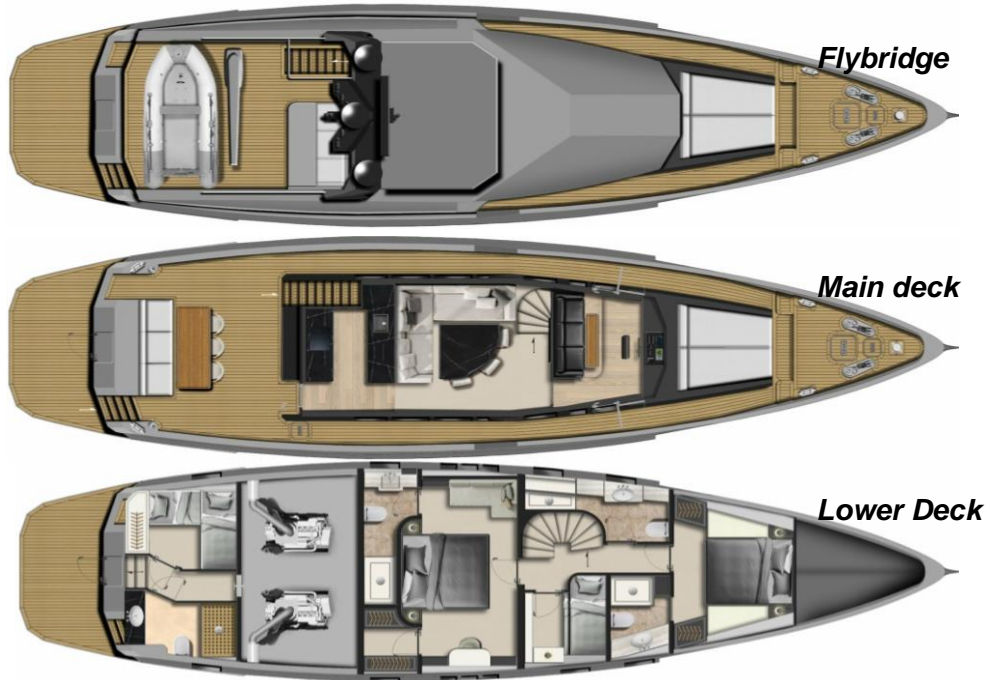

Figure 12. MAGNOLIA - General Arrangement

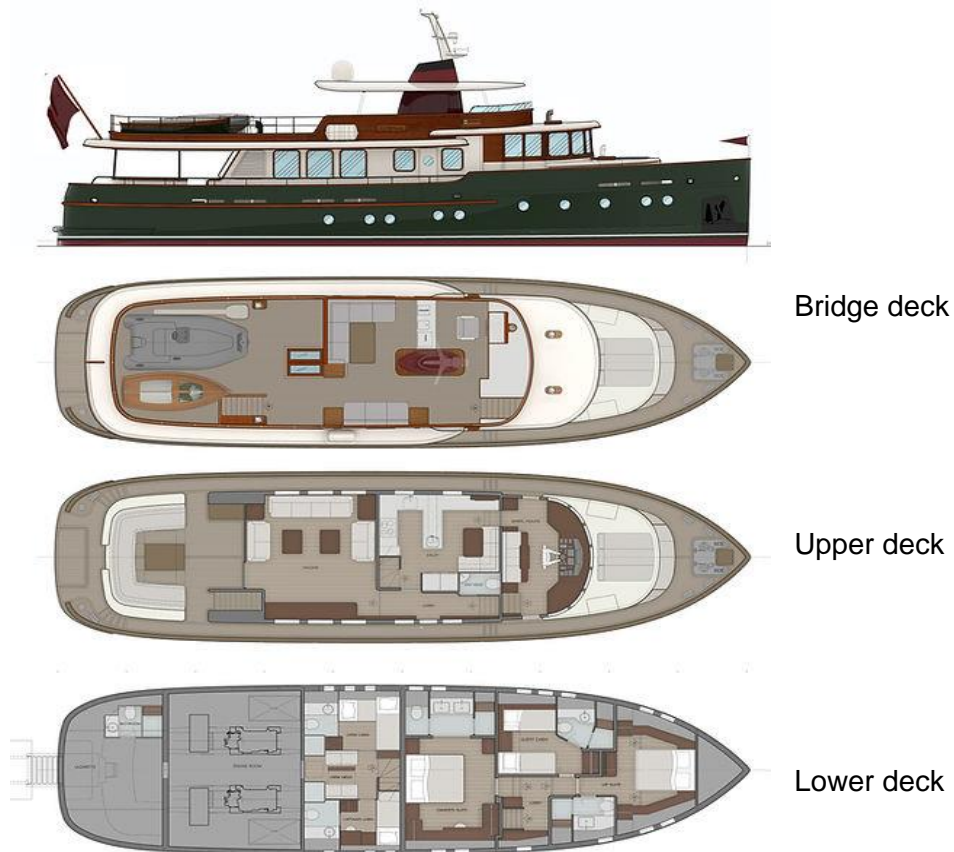
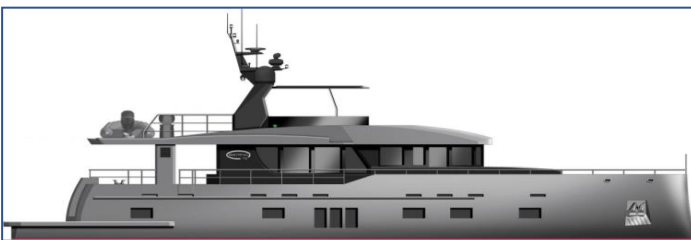

Figure 13. Market Analysis – Exterior Aspect



OKEAN 80 FLY

- More exposed to external
- Main deck foldable
- Semi displacement Hull, Fiber glass/GRP
- Extended panoramic,



BERING B70

- Panoramic from main deck
- Extended bridge deck
- Lower deck also big size windows



MAGNOLIA

- Less panoramic
- Lower deck windows are

Figure 14. Market Analysis – Interior aspect

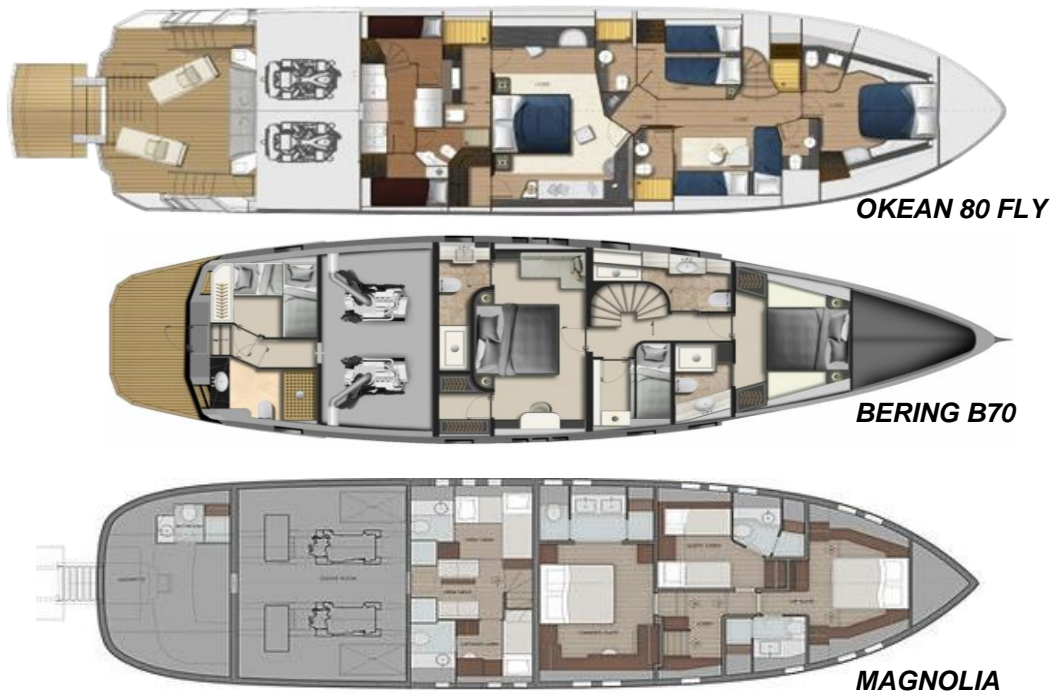
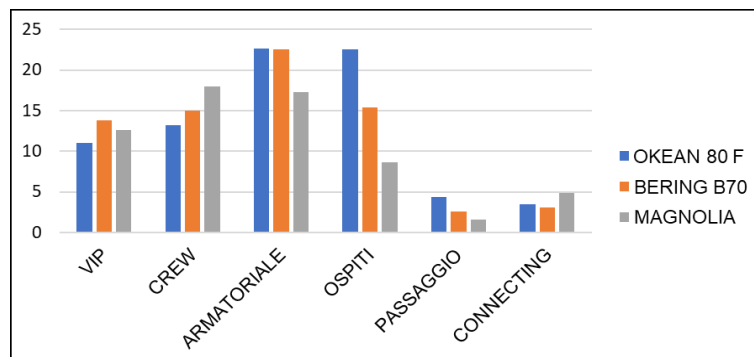
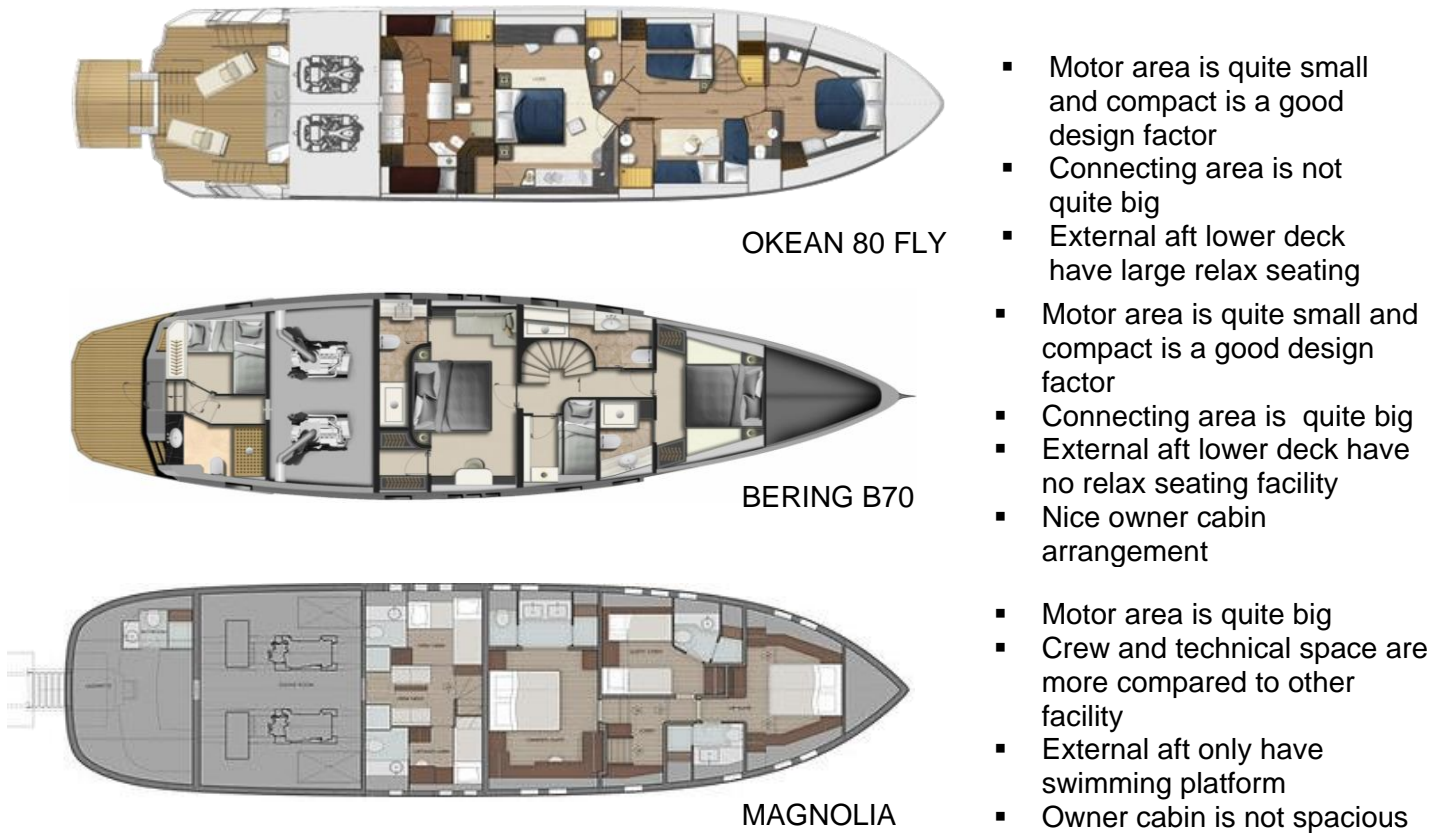

Figure 15. Comparison of interior space



- In ocean 80 fly guest area is more spacious
- Owner space is quite less in Magnolia
- Crew facility is nice in Magnolia
- Internal corridor connection design facilitates in Magnolia
- Unique shape of Bering B70 makes equal judgement for all personnel

Figure 16. Market Analysis – Operational functionality



2.1 Observation on Market analysis

Okean 80 fly and Bering B70 yacht more advance in ergonomic point of view due to large space in owner cabin, spacious main deck and good connecting between spaces.

Okean 80 fly is the best to enjoy panoramic view among all three yachts. In Magnolia Yacht at lower deck the passaggio and their connections are not designed properly. Crew spaces have been separated from Guest areas in all three yachts. However, In Okean 80 Fly has spent less space for crew passaggio, means utilize properly to get more facility at aft lower deck. Only Magnolia yacht has the washing facility before and after swimming at lower aft deck area. Magnolia Yacht has spent more space for technical and storage compared to owner cabin.

OKEAN 80 Fly has the more relax zone than other two yachts.

Visibility in lower deck is comparatively lesser in MAGNOLIA due to the shape of windows.

3. Characteristic of yacht

Principal Particulars

- Length Overall, LOA = 24.00 meter
- Length water line LWL = 23.36 meter
- Breadth B = 6.95 meter
- Depth D = 3.65 meter
- Draught T = 1.78 meter
- Displacement Δ = 130 MT
- Block Coefficient C_B = 0.453
- Speed Cruising V = 11.5 Knots
- Maximum Speed V = 12.5 Knots
- Fuel Oil 3600 L x 2 No
- Fresh water 4500 L
- Grey water 990 L
- Black water 975 L
- Hull Material Aluminium Grade H5082
- Guest 8
- Crew 3
- Engine and Propulsion AZIPOD, IPS600 VOLVO PENTA x 2 No
@3500 Rpm, 307 KW each
- Fuel Consumption 11.5 Knots, 85L/hours
- Sea Route Genoa to Malta



4. Displacement

Displacement is one of the most important criteria of our boat. The displacement is directly related to draft and based on draft the vessel resistance and consequently the speed impact and finally the power requirement to navigate the yacht.

To be more and more precise in displacement value we carried out three phases of verifications.

- Market analysis of displacement
- Manual Calculation of displacement
- Displacement using Stability software

4.1 Market Analysis on Displacement

 <p>https://itboat.com/models/6932-bering-75</p>	<p><u>Bering 75 Yacht</u></p> <p>L = 23 m, B = 6.80 m, d = 1.80m Hull- Steel, Displacement Cabins 3 + 1 (owner), Guests 6+2 crew Maximum speed 11 kn Cruising speed 8 kn Displacement, half load 158m t Fuel 26500 L, Fresh water 3800 L Stern drive 2x Cummins QSM 11 300 n.c.</p>
 <p>https://itboat.com/models/16303-bering-78</p>	<p><u>Bering 78 Yacht</u></p> <p>LOA = 23.85 m LWL = 23.55m Beam = 6.52 m, d= 1.45m 6+2 crew, Full displacement hull, steel+aluminium 6 guests+2 crew Cruise 8 kn, max 10 knots Fuel 11700 L, Fresh water 2500 L, GT -109 Displacement – 96.1 Mt 2xQSB 9285 Hp Diesel Engine</p>
 <p>https://itboat.com/models/6486-black-sea-yachts-bsy-80</p>	<p><u>BLACK SEA YACHTS BSY 80</u></p> <p>LOA = 23.80 m Breadth = 6.70 m Draft = 1.90 m 8+2 crew, Displacement hull, steel hull all Cruise 9 kn, max 11.5 knots Fuel 16000 L, Fresh water 5400 L Displacement – 117.50 Mt 2xVolvo penta d9, 425 hp</p>

	<p><u>Magnolia</u> LOA = 23.99 m, L BP =23.80m Breadth = 6.40 m Draft = 1.60 m,6+3 crew, Round bilge with soft deep skeg spary chine Hull Material – Wooden material Cruise 12 Knots, Max 14 knots Fuel 7000L, F water 2200 L,Sewage -3000 L Displacement – 80 Mt 2x600 HP, 2X Gearbox ZF 325-1</p>
	<p><u>OKAN 80 Fly</u> LOA = 23.90 m, B= 6.50 m, d = 1.76 m 8+2 crew, Semi Displacement hull, Hull Material GRP/Fiberglass Max 25 knots Fuel 5745L, Fresh water 1690 L black water -685 L Displacement – 84 Mt 2x1550 MAN, Shaft drive</p>
	<p><u>Codices Vero</u> LOA = 24.00 m Breadth = 6.5 m Draft = 1.40 m 8+4 crew, V shape hull, all aluminium Cruise 20 kn, max 25 knots Fuel 10000 L, Fresh water 2000 L Displacement – 90 Mt 2xMAN 1550HP@2300 RPM</p>

4.1.1 Displacement summary from Market analysis

Yacht	Length OA, m	B, m	d, m	Displacement (MT)	Hull Type	Mat	Cruise Speed
Bering 75	23	6.8	1.8	158	Displacement	Steel	8
Bering 78	23.85	6.52	1.45	96.1	Displacement	Steel+Al	8
BSY 80	23.8	6.7	1.9	117.5	Displacement	Steel	9
Magnolia	23.99	6.4	1.6	80		wood	12
OKAN 80 Fly	23.9	6.5	1.76	84	Displacement	GRP	10
Codecasa Vero	24	6.5	1.4	90	Planning	Al	20

From the above, if the boat material is steel or aluminium or a combination of both displacement varies between 90MT to a maximum 158MT whereas for GRP and wood, it is less than 90 MT.

4.2 Detail Displacement Calculation

SERENE has been divided into total five (05) different zones and weight has been calculated for each zone separately.

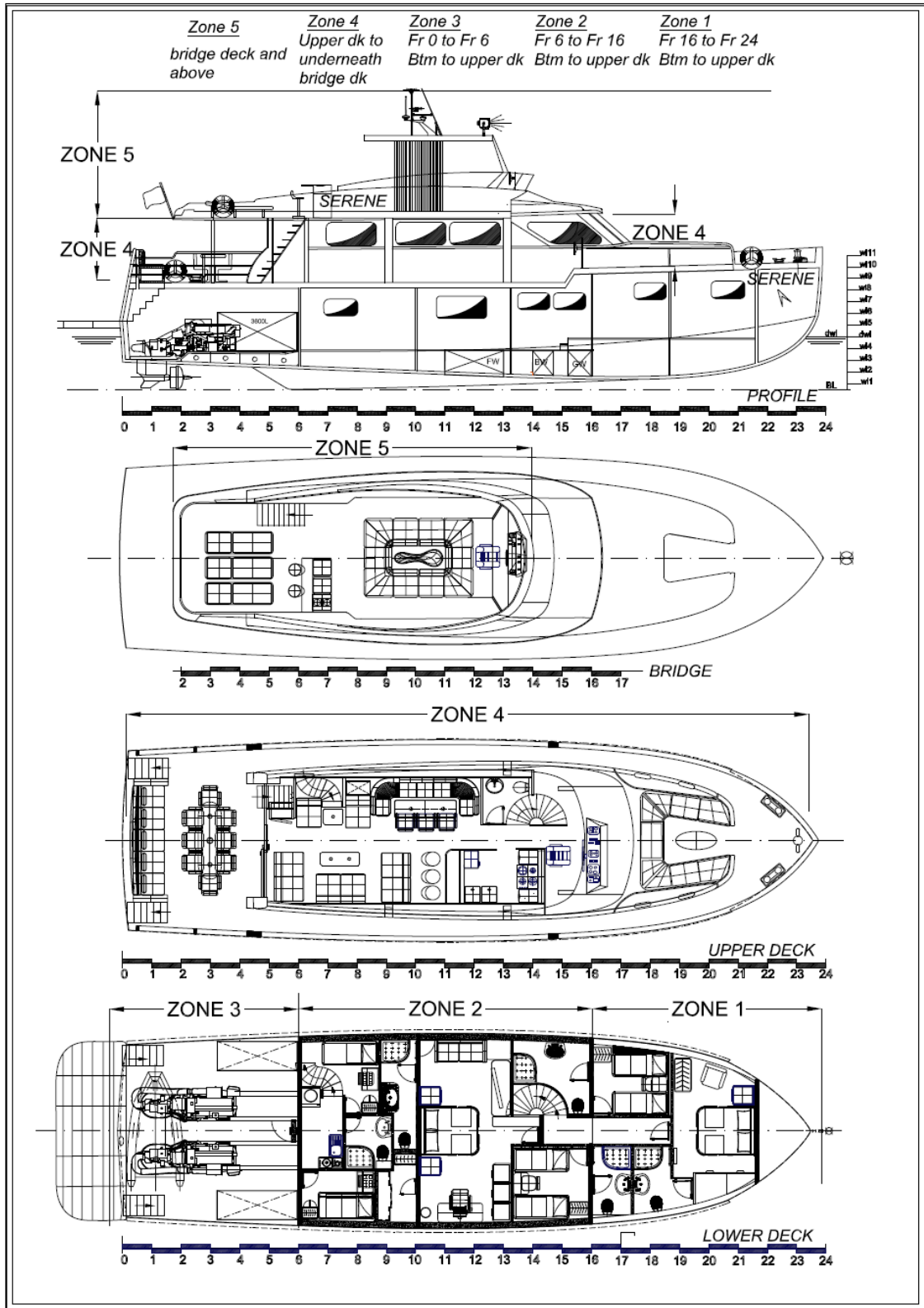

Table 1. Weight calculation for each zone

No	Items description	Weight	LCG	VCG	TCG	PS-SB	Weight x LCG	Weight x VCG	Weight x TCG
		Kg	m	m	m	Center	Kg-m	Kg-m	Kg-m
1	Structural weight (all)	5230	19.676	2.271	0	C	102905.48	11877.33	0
2	Double Bed 1 no.	275	19.8	2.4	0	C	5445	660	0
3	Side locker	90	21.184	2.4	1.208	p	1906.56	216	108.72
4	Side sofa	120	20.178	2.5	1.942	P	2421.36	300	233.04
5	Hanger	50	19.044	2.7	1.826	P	952.2	135	91.3
6	Wooden locker	150	20.5	2.7	1.94	S	3075	405	-291
7	Floor material	650	20.318	1.78	0.4	P	13206.7	1157	260
8	Insulation and paneling sides	700	20.318	3.155	0	C	14222.6	2208.5	0
9	Ceiling on top	350	20.318	4	0.15	P	7111.3	1400	52.5
10	cables and lights, switches etc	175	20.6	3.8	0.2	p	3605	665	35
11	TV	75	18.75	3.45	0.7	S	1406.25	258.75	-52.5
12	Door	150	18.5	3.2	0	C	2775	480	0
13	Paint works board	125	18.7	3.25	0.8	P	2337.5	406.25	100
14	side windowsx2	300	20.66	3.3	0	C	6198	990	0
15	Ventilation duct center ceiling	175	19.41	3.77	0	C	3396.75	659.75	0
16	Portable fire extinguisher	90	18.75	2.45	0.765	S	1687.5	220.5	-68.85
17	Bhd at frame 21+635	360	19	2.5	0.15	S	6840	900	-54
18	Toilet module x2	160	17.39	2.08	2.6	S	2782.4	332.8	-416
19	Wash basin x2	160	17.4	2.6	1.96	S	2784	416	-313.6
20	DOOR	120	19	2.38	1.612	S	2280	285.6	-193.44
21	Shower Basin	350	17.39	1.9	0.95	S	6086.5	665	-332.5
22	Door at Fr 16	120	16	2.6	1.78	S	1920	312	-213.6
23	Window x2	300	18	3.35	0	C	5400	1005	0

No	Items Description	Weight	LCG	VCG	TCG	PS-SB	Weight x LCG	Weight x VCG	Weight x TCG
24	Toilet accessories	175	17.5	3.25	1.85	S	3062.5	568.75	-323.75
25	Insulation and paneling sides	575	17.5	3.25	1.81	S	10062.5	1868.75	-1040.75
26	Toilet floor material	250	17.4	1.8	1.8	S	4350	450	-450
27	Lights, switches	150	17.4	1.8	2.7	S	2610	270	-405
28	Piping, valves, fittings	385	17.65	2.4	1.9	S	6795.25	924	-731.5
29	Bunk bed x2	300	17.75	2.2	1.55	P	5325	660	465
30	Hanger	50	16.3	2.15	2.6	P	815	107.5	130
31	Table and chair	250	18.15	2.43	1.55	P	4537.5	607.5	387.5
32	Floor material	375	17.4	1.85	1.56	P	6525	693.75	585
33	Door	150	16.3	2.65	1.2	P	2445	397.5	180
34	Lights, Switches, cables	275	17.65	3.58	1.56	p	4853.75	984.5	429
35	Insulation and paneling sides	650	17.85	2.8	2.95	P	11602.5	1820	1917.5
36	TV and other furnishing	525	16	3.5	1.45	P	8400	1837.5	761.25
37	Vent Duct	275	17.6	3.75	1.3	P	4840	1031.25	357.5
	Zone 1 Total	14660	18.8928	2.60413	0.08232		276969.1	38176.48	1206.82s

No	Items Description	Weight	LCG	VCG	TCG	PS-SB	Weight x LCG	Weight x VCG	Weight x TCG
1	Structural weight	9450	11	2.2	0	C	103950	20790	0
2	Skeg	755	9	0.35	0	C	6795	264.25	0
3	Tank structure	355	14	0.9	0	C	4970	319.5	0
4	Tank Top	1235	11.5	1.35	0	C	14202.5	1667.25	0
5	windows x4	600	14.65	2.84	0	C	8790	1704	0
6	Bigger Window x2	1600	11.5	2.7	0	C	18400	4320	0
7	small windows aft	300	7.5	2.78	0	C	2250	834	0

8	Structural Nhd at Fr 10	550	10	2.23	0	C	5500	1226.5	0
9	Internal partition at Fr.13	850	13.15	2.1	0	C	11177.5	1785	0
10	pipng and fittings, valves	1250	9.25	1.5	0.2	p	11562.5	1875	250
No	Items description	Weight	LCG	VCG	TCG	PS-SB	Weight x LCG	Weight x VCG	Weight x TCG
11	Staircase at 14	350	14.15	2.5	0.985	P	4952.5	875	344.75
12	bunk bed x2	350	14	1.55	1.8	S	4900	542.5	-630
13	hanger	50	15.5	1.8	2.67	S	775	90	-133.5
14	locker	130	13.3	1.7	1.84	S	1729	221	-239.2
15	Paneling	375	14.5	2.5	0.9	S	5437.5	937.5	-337.5
16	Paneling	375	14.5	2.55	0.85	P	5437.5	956.25	318.75
17	Shower bed	150	13.5	1.55	2.1	P	2025	232.5	315
18	Wash basin	90	15	1.98	2.9	P	1350	178.2	261
19	Door stbd	150	15.65	2.3	0.5	S	2347.5	345	-75
20	Toilet	125	15.4	1.4	0.88	P	1925	175	110
21	Door port	150	16	2.3	2.1	P	2400	345	315
22	vent duct	195	14.5	3.4	0	C	2827.5	663	0
23	lights, switches,	350	14.5	3	0	C	5075	1050	0
24	TV	50	16	2.2	2.8	P	800	110	140
25	TV	50	16		2.8	S	800	0	-140
26	Bed and 02 Lockers	350	11	1.7	0	C	3850	595	0
27	Port Sofa	250	11.8	1.6	2.7	P	2950	400	675
28	Stbd Table & Chair, Laptop	450	11.6	1.82	2.6	S	5220	819	-1170
29	Lockers	425	13	1.75	2.1	S	5525	743.75	-892.5
30	Shelves & Croceries	250	13	2.5	2	P	3250	625	500
31	Side Corner table	95	13	1.8	2.7	P	1235	171	256.5
32	TV	50	13.2	2.6	2.2	S	660	130	-110
33	Lights and switches	375	11.5	3.1	0	C	4312.5	1162.5	0
34	Floor Material	475	12	1.4	0	C	5700	665	0
35	Paneling and Insulation	395	12	2.8	0	C	4740	1106	0

36	Ceiling	250	12	3.4	0	C	3000	850	0
37	Cables	250	12	3.4	0	C	3000	850	0
38	Ducts	325	12	3.3	0	C	3900	1072.5	0
39	Pipings and fittings, valves	475	12	1.2	0	C	5700	570	0
No	Items Description	Weight	LCG	VCG	TCG	PS-SB	Weight x LCG	Weight x VCG	Weight x TCG
40	Bookshelf	225	10.5	3	0	C	2362.5	675	0
41	Doorx2	300	10	2.3	0	C	3000	690	0
42	Stbd Bunk Bed	150	7	2.8	1.75	S	1050	420	-262.5
43	Stbd Bunk Bed	150	8.3	2.3	1.75	S	1245	345	-262.5
44	Door	120	7.5	2	1.1	S	900	240	-132
45	Hanger	50	6.3	1.9	1.3	S	315	95	-65
46	Paneling (all)	925	7.5	2	0	C	6937.5	1850	0
47	Table +2x Chairs	195	6.7	1.9	1.2	S	1306.5	370.5	-234
48	Toilet +Fitting	190	8.7	1.6	0.3	S	1653	304	-57
49	Shower basin	310	8.5	1.4	1.2	S	2635	434	-372
50	All cables, Lights, switches	450	7	3.2	0.5	S	3150	1440	-225
51	Toilet Door	120	8	2.2	0.4	P	960	264	48
52	Basin	95	9	1.9	0.4	P	855	180.5	38
53	Galley Basin	95	6.15	2.1	1.1	P	584.25	199.5	104.5
54	Washing Machine	180	8.5	1.8	0.8	P	1530	324	144
55	Escape Staircase	145	7	2.8	2	P	1015	406	290
56	Captain door	120	7.7	2.2	1.2	P	924	264	144
57	Table & Chair	185	8.4	1.9	1.8	P	1554	351.5	333
58	hanger	50	6.3	1.7	2.7	P	315	85	135
59	Bunk Bed Port	130	8	1.8	2.8	P	1040	234	364
60	Piping & Fitting	375	8	1.9	0	C	3000	712.5	0
61	Vent duct piping	275	8	3.4	0	C	2200	935	0
62	2xdoors at 10	260	10	2.2	0	C	2600	572	0
63	Shower Basin	280	9.5	1.45	2.8	P	2660	406	784

64	Basin & Board	190	9.1	1.9	1.8	P	1729	361	342
65	Glass and accessories	350	9	2	1.6	P	3150	700	560
66	Toilet	95	9.5	1.6	0.5	S	902.5	152	-47.5
67	Hanger	50	9.5	1.7	0.9	S	475	85	-45
68	Cloth Locker	320	9	1.7	2.2	S	2880	544	-704
No	Items description	Weight	LCG	VCG	TCG	PS-SB	Weight x LCG	Weight x VCG	Weight x TCG
69	Lights and switches	275	9.5	3.4	0	C	2612.5	935	0
70	Piping, fittings and valves	450	9.5	1.25	2	P	4275	562.5	900
	ZONE 2 TOTAL	31405	10.9294	2.11441	0.04898		343237.25	66403.2	1538.3
1	Tender Boat +support	1900	1	2.7	0	C	1900	5130	0
2	Bhd at Fr. 6	450	6	2.119	0	C	2700	953.55	0
3	Insulation on bhd	650	5.85	2.119	0	C	3802.5	1377.35	0
4	structural weight	980	3.5	1.85	0	C	3430	1813	0
5	Engine Girder Reinforcement	850	3	1.06	0	C	2550	901	0
6	Fire Pump	650	4	1.6	3	p	2600	1040	1950
7	Hvac Unit	3500	4	2	3	p	14000	7000	10500
8	BW/GW Pump	1800	4	1.9	3	S	7200	3420	-5400
9	Genset 10 kw	2500	3.5	2.2	3.5	S	8750	5500	-8750
10	Motorx2	3600	1.5	2	0	C	5400	7200	0
11	Electrical Cabinet	1250	5	2.5	3	C	6250	3125	3750
12	Ceiling/Insulation	550	3	4	0.5	P	1650	2200	275
13	Auxiliary pipes	950	2.5	1.6	0.5	S	2375	1520	-475
14	Cables, switches	575	3	3.4	0	C	1725	1955	0
15	Fire fighting	250	3.5	3.8	0	C	875	950	0
16	Door	200	6	2.2	0	C	1200	440	0
17	Valves and catuators	525	5	1.9	0	C	2625	997.5	0
18	Sea escape platform	1500	0	2.55	0	C	0	3825	0

	ZONE 3 TOTAL	22680	3.04376	2.17581	0.08157		69032.5	49347.4	1850
No	Items description	Weight	LCG	VCG	TCG	PS-SB	Weight x LCG	Weight x VCG	Weight x TCG
1	Structural Item	2650	11.5	4.4	0	C	30475	11660	0
2	Stiffeners, web and bkts	450	11.75	4.8	0	C	5287.5	2160	0
3	Outfitting	325	3	3.8	0	C	975	1235	0
4	Anchor and chain	195	22.5	3.2	0	C	4387.5	624	0
5	Bollards	150	22	4.2	0	C	3300	630	0
6	Towing Bollard	80	23	4.25	0	C	1840	340	0
7	Aft stair case	230	1	3	0	C	230	690	0
8	aft platform	250	0	3	0	C	0	750	0
9	Pillar	50	3	4.5	0	C	150	225	0
10	Windows front	750	15.5	5.3	0	C	11625	3975	0
11	Seating sofa external aft, locker	800	1	4.35	0	C	800	3480	0
12	Table and chairs are external	650	3	4.33	0	C	1950	2814.5	0
13	port and stbd 6 no windows	900	10	5.33	0	C	9000	4797	0
14	Control unit	350	16.25	4.63		C	5687.5	1620.5	0
15	Captain Chair	150	14.7	5.2	0.65	S	2205	780	-97.5
16	Spiral Stair	160	14	3.7	1.1	P	2240	592	176
17	Toilet	130	14	3.7	1.1	P	1820	481	143
18	Wash Basin	175	12.6	4	1.92	P	2205	700	336
19	Door	150	12.6	4.2	0.56	P	1890	630	84
20	Galley Oven, box, locker	525	14	4.1	1.24	S	7350	2152.5	-651
21	Fridge+store	500	12.5	4.2	1.8	S	6250	2100	-900
22	Locker	185	11.8	4.1	0.65	S	2183	758.5	-120.25
23	Panel + Board	425	12.5	4.4	0	C	5312.5	1870	0
24	Light, switch, cables	350	13	5.4	0	C	4550	1890	0
25	Chairsx 3 no	250	10.5	4.1	1.23	S	2625	1025	-307.5

26	Relax sofa	525	10	4.1	1.45	P	5250	2152.5	761.25
27	3 Chairs +Table	400	10.4	4	0.9	P	4160	1600	360
No	Items Description	Weight	LCG	VCG	TCG	PS-SB	Weight x LCG	Weight x VCG	Weight x TCG
28	6 Sofa set + table	800	7.5	4	1.35	S	6000	3200	-1080
29	Sofa +Table	220	7	4	0.85	P	1540	880	187
30	Small Fridge	140	5.5	4.2	1.2	P	770	588	168
31	Vent Duct	385	8	4	1.8	P	3080	1540	693
32	Spiral Staircase	160	7	4.4	1.8	P	1120	704	288
33	Ceiling Material	650	10	5.2	0	C	6500	3380	0
34	Floor Material	1200	10	3.6	0	C	12000	4320	0
35	Insulation + Paneling	1200	10	4.5	0	C	12000	5400	0
36	External Staircase to up	230	5.2	4.4	1.48	P	1196	1012	340.4
37	Sliding Door	230	5	4.4	1.1	P	1150	1012	253
38	Aft Lights + Switches	450	8	5.4	0	C	3600	2430	0
39	Cables	250	8	5.5	0	C	2000	1375	0
40	Wall Paintings	160	7	5	0	C	1120	800	0
41	Pipes, Valves, Fittings	500	14	4	0	C	7000	2000	0
42	External Sofa FWD	375	19	4.2	0	C	7125	1575	0
	ZONE 4 TOTAL	18705	10.155	4.3811	0.03386		189949	81948.5	633.4

No	Items Description	Weight	LCG	VCG	TCG	PS-SB	Weight x LCG	Weight x VCG	Weight x TCG
1	Sun Bed x 3	300	4	6.18	0.34	P	1200	1854	102
2	Wash, Oven, Cup Board	500	6.75	6.5	0.931	S	3375	3250	-465.5
3	Round chair +Table	450	6	6.4	0.8	S	2700	2880	-360
4	Relax Seating	900	10	6.2	0	C	9000	5580	0
5	Centre Vertical Mast and awning	350	9.5	7.46	0	C	3325	2611	0
6	Control Unit	380	13.5	6.7	0	C	5130	2546	0
7	Structural Weight	1550	12	6.7	0	C	18600	10385	0
8	Navigational Antenna+ Radar	700	11.5	8.5	0	C	8050	5950	0
9	Anchor + Navigation Lights	350	12	9.8	0	C	4200	3430	0
10	Navigation upper deck	250	15.65	5.34	0.8	S	3912.5	1335	-200
11	Awning	350	11	8.5	0	C	3850	2975	0
12	Painting all-around external	8000	11	2.9	0	C	88000	23200	0
	ZONE 5 TOTAL	14080	10.7488	4.68722	-0.0656		151342.5	65996	-923.5

4.2.1 Summary of Lightship

Summary of weight	Weight	LCG	VCG	TCG		Weight x LCG	Weight x VCG	Weight x TCG
	Kg	m	m	m		Kg-m	Kg-m	Kg-m
Zone 1	14660	18.8928	2.60413	0.08232	P	276969.1	38176.48	1206.82
Zone 2	31405	10.9294	2.11441	0.04898	P	343237.25	66403.2	1538.3
Zone 3	22680	3.04376	2.17581	0.08157	P	69032.5	49347.4	1850
Zone 4	18705	10.155	4.3811	0.03386	P	189949	81948.5	633.4
Zone 5	14080	10.7488	4.68722	-0.0656	S	151342.5	65996	-923.5
LIGHTSHIP	101530	10.15	2.97323	0.0424	P	1030530.35	301871.58	4305.02
LIGHTSHIP	101530	10.15001	2.973225	0.042401	P	1030530.35	301871.58	4305.02
Crew	240	7.75	2.1	-1.8	S	1860	504	-432
Guest +owner	880	16	2.1	0	C	14080	1848	0
FINAL LIGHTSHIP	102650	10.19455	2.963698	0.03773	P	1046470.35	304223.58	3873.02

4.2.2 Voyage, Mid voyage, and Arrival Condition

Condition 1: Voyage Consumables 100%							Weight x LCG	Weight x VCG	Weight x TCG
No	Items	Kg	LCG	VCG	TCG	PS-SB	Kg-m	Kg-m	Kg-m
1	FINAL LIGHTSHIP	102650	10.1945	2.9637	0.03773	P	1046470.35	304223.58	3873.02
2	F.O.	6120	4.6	1.966	0		28152	12031.92	0
3	Fresh water	4500	11.75	0.9	0		52875	4050	0
4	Grey water	0	15.55	0.85	0		0	0	0
5	Black water	0	14.45	0.87	0		0	0	0
6	Foods	3500	12	4.3	0		42000	15050	0
		116770	10.0154	2.87193	0.03317	P	1169497.35	335355.5	3873.02

Condition 2: Mid Voyage 50% Consumables							Weight x LCG	Weight x VCG	Weight x TCG
No	Items	Kg	LCG	VCG	TCG	PORT- STBD	Kg-m	Kg-m	Kg-m
1	FINAL LIGHTSHIP	102650	10.1945	2.9637	0.03773	P	1046470.35	304223.58	3873.02
2	F.O.	3060	4.6	1.65	0		14076	5049	0
3	Fresh water	2250	12.25	0.68	0		27562.5	1530	0
4	Grey water	485	15.65	0.58	0		7590.25	281.3	0
5	Black water	475	14.55	0.6	0		6911.25	285	0
6	Foods	1750	12	3.8	0		21000	6650	0
		110670	10.1528	2.87358	0.035	P	1123610.35	318018.88	3873.02

Condition 3: Arrival 10% Consumables							Weight x LCG	Weight x VCG	Weight x TCG
No	Items	Kg	LCG	VCG	TCG	PORT- STBD	Kg-m	Kg-m	Kg-m
1	FINAL LIGHTSHIP	102650	10.1945	2.9637	0.03773	P	1046470.35	304223.58	3873.02
2	F.O.	612	4.6	1.42	0		2815.2	869.04	0
3	Fresh water	450	12.45	0.54	0		5602.5	243	0
4	Grey water	980	15.7	0.43	0		15386	421.4	0
5	Black water	970	14.6	0.44	0		14162	426.8	0
6	Foods	350	12	2.9	0		4200	1015	0
		106012	10.269	2.89777	0.03653	P	1088636.05	307198.82	3873.02
Summary									
		Displacement (MT)		LCG in meter		VCG in meter		TCG in meter	
Condition 1: 100% Consumables		116.77		10.015		2.872		0.033	
Condition 2: 50% consumables		110.67		10.153		2.874		0.035	
Condition 3: 10% Consumables		106.012		10.269		2.898		0.037	

4.3 Displacement using Software

A 3d surface model has been created using Rhino 3D and import to Maxsurf and displacement has been generated by software 130.532 MT. Maxsurf result included in Resistance and power calculation part.

5. Stability Check

Manual calculated displacement value used to iterate the GZ value in three different conditions.

5.1 Cross Curves results for even keel condition (no trim)

TABLES OF RIGHTING LEVER (KN VALUE)									
=====									
NOTES:									
=====									
1) COMPUTATIONS INCLUDE HULL UP TO MAIN DECK.									
2) COMPUTATIONS ARE DONE ASSUMING FREE TRIM WHILE HEELING.									
3) SPECIFIC GRAVITY OF SALT WATER = 1.025.									
CROSS CURVES OF STABILITY									
Showing righting arms in heel at VCG = 0.00 Trim: zero at zero heel (trim righting arm held at zero)									
Displacement METRIC TONS	Heeling Angle in degrees								
	5.00 s	10.00 s	20.00 s	30.00 s	40.00s	50.00 s	60.00 s	70.00 s	80.00 s
100.00	0.501 s	0.948 s	1.675 s	2.210 s	2.605 s	2.891 s	2.991 s	2.931 s	2.751 s
101.00	0.499 s	0.945 s	1.671 s	2.207 s	2.604 s	2.890 s	2.988 s	2.928 s	2.749 s
102.00	0.497 s	0.942 s	1.667 s	2.204 s	2.602 s	2.888 s	2.985 s	2.926 s	2.747 s
103.00	0.495 s	0.938 s	1.663 s	2.202 s	2.601 s	2.886 s	2.982 s	2.923 s	2.744 s
104.00	0.492 s	0.935 s	1.660 s	2.199 s	2.600 s	2.884 s	2.979 s	2.920 s	2.742 s
105.00	0.490 s	0.932 s	1.656 s	2.196 s	2.598 s	2.882 s	2.976 s	2.917 s	2.740 s
106.00	0.488 s	0.929 s	1.653 s	2.194 s	2.597 s	2.880 s	2.973 s	2.915 s	2.738 s
107.00	0.485 s	0.926 s	1.649 s	2.191 s	2.596 s	2.878 s	2.970 s	2.912 s	2.735 s
108.00	0.483 s	0.923 s	1.645 s	2.188 s	2.594 s	2.876 s	2.968 s	2.909 s	2.733 s
109.00	0.481 s	0.919 s	1.642 s	2.186 s	2.593 s	2.873 s	2.965 s	2.906 s	2.731 s
110.00	0.478 s	0.916 s	1.638 s	2.183 s	2.592 s	2.871 s	2.962 s	2.904 s	2.729 s
111.00	0.476 s	0.913 s	1.635 s	2.180 s	2.591 s	2.868 s	2.959 s	2.901 s	2.727 s
112.00	0.474 s	0.910 s	1.631 s	2.178 s	2.589 s	2.866 s	2.956 s	2.898 s	2.724 s
113.00	0.472 s	0.907 s	1.628 s	2.175 s	2.588 s	2.863 s	2.953 s	2.895 s	2.722 s
114.00	0.469 s	0.904 s	1.624 s	2.173 s	2.587 s	2.860 s	2.950 s	2.893 s	2.720 s
115.00	0.467 s	0.901 s	1.621 s	2.170 s	2.585 s	2.858 s	2.947 s	2.890 s	2.718 s
116.00	0.465 s	0.898 s	1.618 s	2.168 s	2.584 s	2.855 s	2.944 s	2.887 s	2.716 s
117.00	0.463 s	0.895 s	1.614 s	2.165 s	2.582 s	2.852 s	2.941 s	2.884 s	2.714 s
118.00	0.461 s	0.892 s	1.611 s	2.163 s	2.581 s	2.849 s	2.938 s	2.882 s	2.711 s
119.00	0.459 s	0.890 s	1.608 s	2.160 s	2.579 s	2.846 s	2.934 s	2.879 s	2.709 s
120.00	0.457 s	0.887 s	1.605 s	2.158 s	2.578 s	2.843 s	2.931 s	2.876 s	2.707 s
121.00	0.454 s	0.884 s	1.601 s	2.155 s	2.577 s	2.841 s	2.928 s	2.874 s	2.705 s
122.00	0.452 s	0.881 s	1.598 s	2.153 s	2.575 s	2.838 s	2.925 s	2.871 s	2.703 s
123.00	0.450 s	0.878 s	1.595 s	2.150 s	2.573 s	2.835 s	2.922 s	2.868 s	2.701 s
124.00	0.448 s	0.875 s	1.592 s	2.148 s	2.572 s	2.832 s	2.919 s	2.865 s	2.699 s

Displacement METRIC TONS	Heeling Angle in degrees								
	5.00 s	10.00 s	20.00 s	30.00 s	40.00s	50.00 s	60.00 s	70.00 s	80.00 s
125.00	0.447 s	0.872 s	1.588 s	2.146 s	2.570 s	2.829 s	2.916 s	2.863 s	2.697 s
126.00	0.445 s	0.870 s	1.585 s	2.143 s	2.569 s	2.826 s	2.913 s	2.860 s	2.695 s
127.00	0.443 s	0.867 s	1.582 s	2.141 s	2.567 s	2.823 s	2.910 s	2.857 s	2.693 s
128.00	0.441 s	0.864 s	1.579 s	2.139 s	2.565 s	2.820 s	2.906 s	2.854 s	2.691 s
129.00	0.439 s	0.861 s	1.576 s	2.136 s	2.563 s	2.817 s	2.903 s	2.852 s	2.688 s
130.00	0.437 s	0.859 s	1.573 s	2.134 s	2.562 s	2.814 s	2.899 s	2.849 s	2.686 s
131.00	0.435 s	0.856 s	1.570 s	2.132 s	2.560 s	2.811 s	2.896 s	2.846 s	2.684 s
132.00	0.434 s	0.853 s	1.567 s	2.129 s	2.558 s	2.808 s	2.892 s	2.843 s	2.682 s
133.00	0.432 s	0.851 s	1.564 s	2.127 s	2.556 s	2.805 s	2.889 s	2.841 s	2.680 s
134.00	0.430 s	0.848 s	1.561 s	2.125 s	2.554 s	2.802 s	2.885 s	2.838 s	2.678 s
135.00	0.429 s	0.845 s	1.558 s	2.123 s	2.552 s	2.799 s	2.882 s	2.835 s	2.676 s
136.00	0.427 s	0.843 s	1.555 s	2.120 s	2.550 s	2.796 s	2.878 s	2.833 s	2.674 s
137.00	0.425 s	0.840 s	1.552 s	2.118 s	2.548 s	2.793 s	2.875 s	2.830 s	2.672 s
138.00	0.424 s	0.838 s	1.549 s	2.116 s	2.546 s	2.790 s	2.871 s	2.827 s	2.670 s
139.00	0.422 s	0.835 s	1.546 s	2.114 s	2.544 s	2.787 s	2.868 s	2.824 s	2.668 s
140.00	0.420 s	0.832 s	1.543 s	2.111 s	2.542 s	2.784 s	2.865 s	2.822 s	2.666 s
141.00	0.419 s	0.830 s	1.541 s	2.109 s	2.540 s	2.781 s	2.861 s	2.819 s	2.664 s
142.00	0.417 s	0.827 s	1.538 s	2.107 s	2.538 s	2.777 s	2.858 s	2.816 s	2.662 s
143.00	0.416 s	0.825 s	1.535 s	2.105 s	2.535 s	2.774 s	2.854 s	2.814 s	2.661 s
144.00	0.414 s	0.822 s	1.532 s	2.103 s	2.533 s	2.771 s	2.851 s	2.811 s	2.659 s
145.00	0.413 s	0.820 s	1.529 s	2.101 s	2.531 s	2.768 s	2.848 s	2.808 s	2.657 s
146.00	0.411 s	0.817 s	1.527 s	2.099 s	2.529 s	2.765 s	2.845 s	2.805 s	2.655 s
147.00	0.410 s	0.815 s	1.524 s	2.097 s	2.526 s	2.762 s	2.841 s	2.803 s	2.653 s
148.00	0.409 s	0.812 s	1.521 s	2.094 s	2.524 s	2.758 s	2.838 s	2.800 s	2.651 s
149.00	0.407 s	0.810 s	1.519 s	2.092 s	2.522 s	2.755 s	2.835 s	2.797 s	2.649 s
150.00	0.406 s	0.807 s	1.516 s	2.090 s	2.520 s	2.752 s	2.832 s	2.795 s	2.647 s

5.2 Hydrostatic Properties

Hydrostatic properties have been calculated using software as follows:

HYDROSTATIC PROPERTIES								
No Trim, No Heel,				Fixed VCG = 0.000				
Distances in METERS. Draft is from Baseline.				Moment in m.-MT.		Specific Gravity = 1.025.		
		Frame 0 /From base						
	Displacement	Buoyancy-Ctr.		Weight/c m	From Fr. 0	Moment/c m trim	KML m	KMT m
Draft (m)	Weight(MT)	LCB (m)	VCB(m)		LCF(m)			
1.390	78.92	11.039 f	1.039	1.36	10.284 f	2.10	62.07	6.652
1.400	80.28	11.026 f	1.045	1.36	10.302 f	2.11	61.28	6.608
1.410	81.65	11.014 f	1.051	1.37	10.315 f	2.11	60.50	6.539
1.420	83.01	11.003 f	1.057	1.37	10.328 f	2.12	59.73	6.472
1.430	84.38	10.992 f	1.063	1.37	10.340 f	2.13	58.97	6.407
1.440	85.75	10.982 f	1.069	1.37	10.357 f	2.14	58.28	6.362
1.450	87.13	10.972 f	1.075	1.38	10.371 f	2.15	57.59	6.307
1.460	88.51	10.963 f	1.081	1.38	10.383 f	2.16	56.91	6.247
1.470	89.89	10.954 f	1.087	1.38	10.400 f	2.17	56.28	6.203
1.480	91.27	10.946 f	1.092	1.38	10.411 f	2.17	55.63	6.144
1.490	92.66	10.938 f	1.098	1.39	10.423 f	2.18	55.00	6.086
1.500	94.04	10.930 f	1.104	1.39	10.434 f	2.19	54.38	6.030
1.510	95.43	10.923 f	1.110	1.39	10.445 f	2.20	53.78	5.976
1.520	96.83	10.916 f	1.116	1.39	10.457 f	2.21	53.20	5.924
1.530	98.22	10.910 f	1.122	1.40	10.476 f	2.21	52.68	5.893
1.540	99.62	10.904 f	1.127	1.40	10.486 f	2.22	52.12	5.842
1.550	101.02	10.898 f	1.133	1.40	10.496 f	2.23	51.57	5.791
1.560	102.42	10.893 f	1.139	1.40	10.506 f	2.24	51.03	5.743
1.570	103.82	10.888 f	1.145	1.40	10.515 f	2.24	50.49	5.695
1.580	105.23	10.883 f	1.151	1.41	10.525 f	2.25	49.98	5.649
1.590	106.63	10.878 f	1.156	1.41	10.544 f	2.26	49.56	5.624
1.600	108.04	10.874 f	1.162	1.41	10.553 f	2.27	49.06	5.578
1.610	109.45	10.870 f	1.168	1.41	10.562 f	2.28	48.58	5.534
1.620	110.87	10.866 f	1.173	1.41	10.570 f	2.28	48.10	5.491
1.630	112.28	10.862 f	1.179	1.42	10.579 f	2.29	47.64	5.449
1.640	113.70	10.859 f	1.185	1.42	10.588 f	2.30	47.18	5.408
1.650	115.11	10.856 f	1.190	1.42	10.596 f	2.30	46.74	5.368
1.660	116.53	10.852 f	1.196	1.42	10.605 f	2.31	46.31	5.330
1.670	117.95	10.850 f	1.202	1.42	10.623 f	2.32	45.97	5.308
1.680	119.38	10.847 f	1.207	1.42	10.631 f	2.33	45.54	5.270
1.690	120.80	10.844 f	1.213	1.43	10.639 f	2.33	45.13	5.233
1.700	122.23	10.842 f	1.219	1.43	10.646 f	2.34	44.72	5.196
1.710	123.66	10.840 f	1.224	1.43	10.654 f	2.35	44.33	5.161

Draft (m)	Weight (MT)	LCB (m)	VCB(m)	Weight/c m	LCF (m)	Moment/c m trim	KML, m	KMT, m
1.720	125.09	10.838 f	1.230	1.43	10.661 f	2.35	43.94	5.127
1.730	126.52	10.836 f	1.235	1.43	10.667 f	2.36	43.54	5.093
1.740	127.95	10.834 f	1.241	1.43	10.675 f	2.36	43.17	5.060
1.750	129.38	10.832 f	1.247	1.43	10.682 f	2.37	42.80	5.028
1.760	130.81	10.831 f	1.252	1.44	10.700 f	2.38	42.54	5.010
1.770	132.25	10.829 f	1.258	1.44	10.706 f	2.39	42.18	4.978
1.780	133.69	10.828 f	1.263	1.44	10.712 f	2.39	41.82	4.947
1.790	135.13	10.827 f	1.269	1.44	10.718 f	2.40	41.47	4.917
1.800	136.57	10.826 f	1.274	1.44	10.724 f	2.40	41.13	4.888
1.810	138.01	10.825 f	1.280	1.44	10.730 f	2.41	40.80	4.859
1.820	139.45	10.824 f	1.286	1.44	10.737 f	2.42	40.46	4.831
1.830	140.89	10.823 f	1.291	1.44	10.743 f	2.42	40.14	4.804
1.840	142.34	10.822 f	1.297	1.44	10.749 f	2.43	39.83	4.777
1.850	143.78	10.821 f	1.302	1.45	10.754 f	2.43	39.52	4.751
1.860	145.23	10.821 f	1.308	1.45	10.772 f	2.44	39.32	4.735
1.870	146.68	10.820 f	1.313	1.45	10.777 f	2.45	39.01	4.710
1.880	148.130	10.820 f	1.319	1.450	10.782 f	2.450	38.710	4.684
1.890	149.580	10.820 f	1.324	1.450	10.787 f	2.460	38.410	4.660
1.900	151.030	10.819 f	1.330	1.450	10.791 f	2.460	38.120	4.636

5.2.1 Hydrostatic Curves

Hydrostatic curves have been drawn using Maxsurf against different draft condition

Figure 17. Hydrostatic Curves

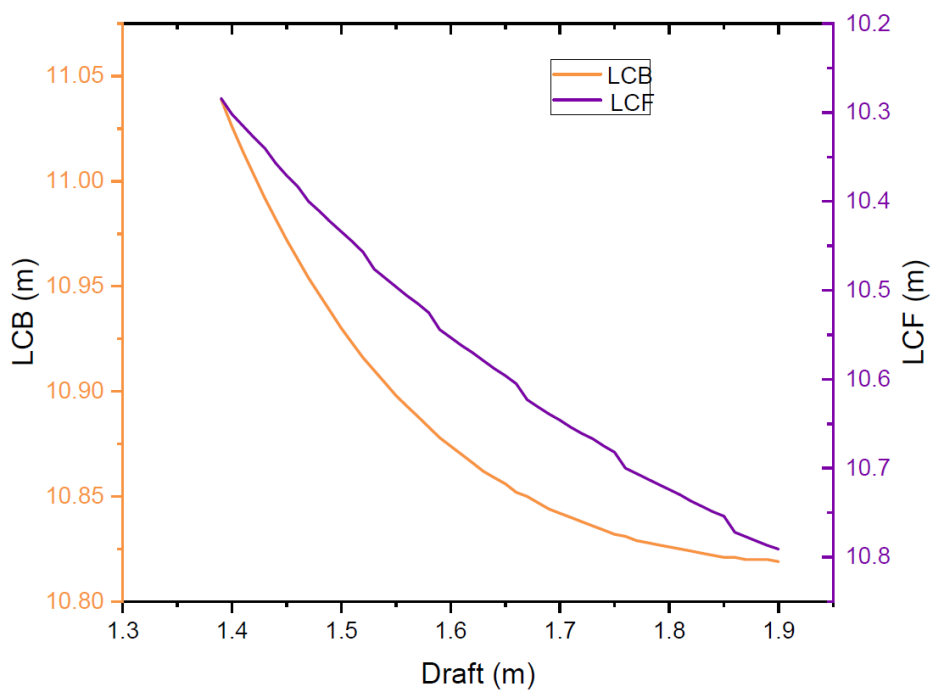
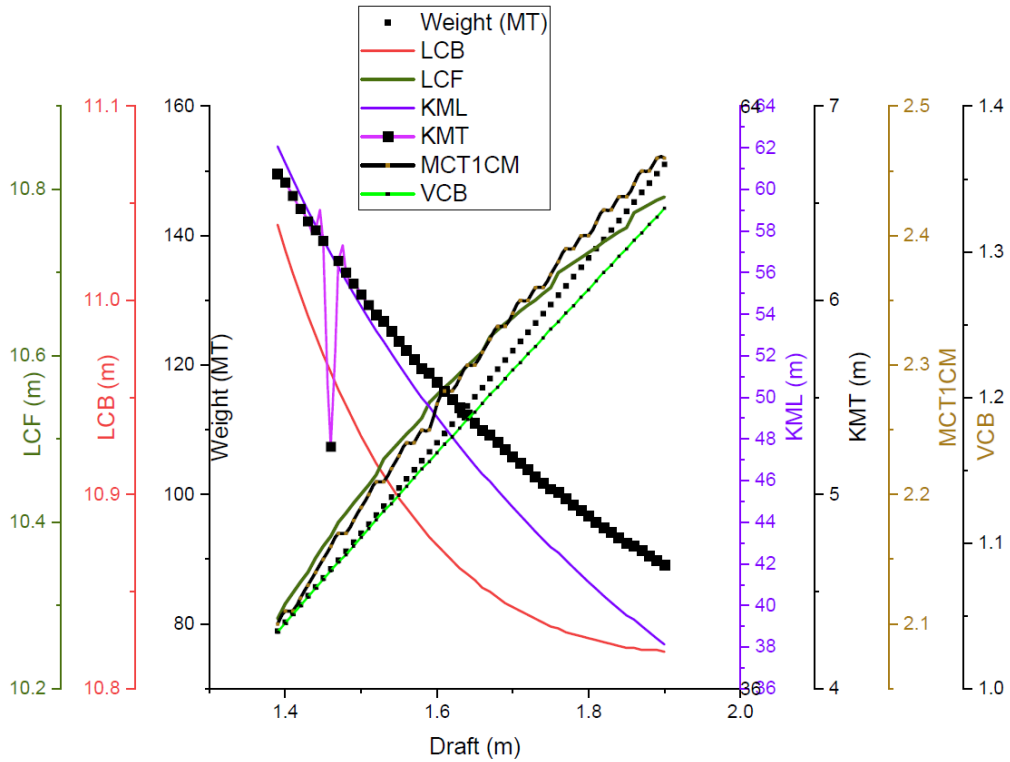

5.3 KN Values in voyage, mid-voyage and arrival condition

Summary									
	Displacement (MT)	LCG in meter			VCG in meter			TCG in meter	
Condition 1: 100% Consumables	116.770	10.015			2.872			0.033	
Condition 2: 50% Consumables	110.670	10.153			2.874			0.035	
Condition 3: 10% Consumables	106.012	10.269			2.898			0.037	
Displacement in MT	KN Values in different heeling angl								
	5 S	10 S	20 S	30 S	40 S	50 S	60 S	70S	80 S
107	0.485	0.926	0.649	2.191	2.596	2.878	2.97	2.912	2.735
106	0.488	0.929	1.653	2.194	2.597	2.88	2.973	2.915	2.738
M	-0.003	-0.003	-1.004	-0.003	-0.001	-0.002	-0.003	-0.003	-0.003
m*(x-x1)	-4E-05	-3.6E-05	-0.012	-4E-05	-1E-05	-2E-05	-4E-05	-4E-05	-4E-05
106.012	0.488	0.929	1.641	2.194	2.597	2.880	2.973	2.915	2.738
111	0.476	0.913	1.635	2.18	2.591	2.868	2.959	2.901	2.727
110	0.478	0.916	1.638	2.183	2.592	2.871	2.962	2.904	2.729
M	-0.002	-0.003	-0.003	-0.003	-0.001	-0.003	-0.003	-0.003	-0.002
m*(x-x1)	-0.0013	-	-0.002	-0.002	-	-0.002	-0.002	-0.002	-
110.67	0.477	0.914	1.636	2.181	2.591	2.869	2.960	2.902	2.728
117	0.463	0.895	1.614	2.165	2.582	2.852	2.941	2.884	2.714
116	0.465	0.898	1.618	2.168	2.584	2.855	2.944	2.887	2.716
M	-0.002	-0.003	-0.004	-0.003	-0.002	-0.003	-0.003	-0.003	-0.002
m*(x-x1)	-0.0015	-	-	-	-	-	-	-	-
116.77	0.463	0.896	1.615	2.166	2.582	2.853	2.942	2.885	2.714

5.3.1 Summary of KN Values

Summary				
	Displacement (MT)	LCG in meter	VCG in meter	TCG in meter
Condition 1: 100% Load	116.770	10.015	2.872	0.033
Condition 2: 50% Load	110.670	10.153	2.874	0.035
Condition 3: 10% Load	106.012	10.269	2.898	0.037

KN Values in different heeling angle (meter)									
Displacement in MT	5 S	10 S	20 S	30 S	40 S	50 S	60 S	70S	80 S
106.012	0.488	0.929	1.641	2.194	2.597	2.880	2.973	2.915	2.738
110.670	0.477	0.914	1.636	2.181	2.181	2.869	2.960	2.902	2.728
116.770	0.463	0.896	1.615	2.166	2.582	2.853	2.942	2.885	2.714

5.3.2 Tanks dimension for free surface correction

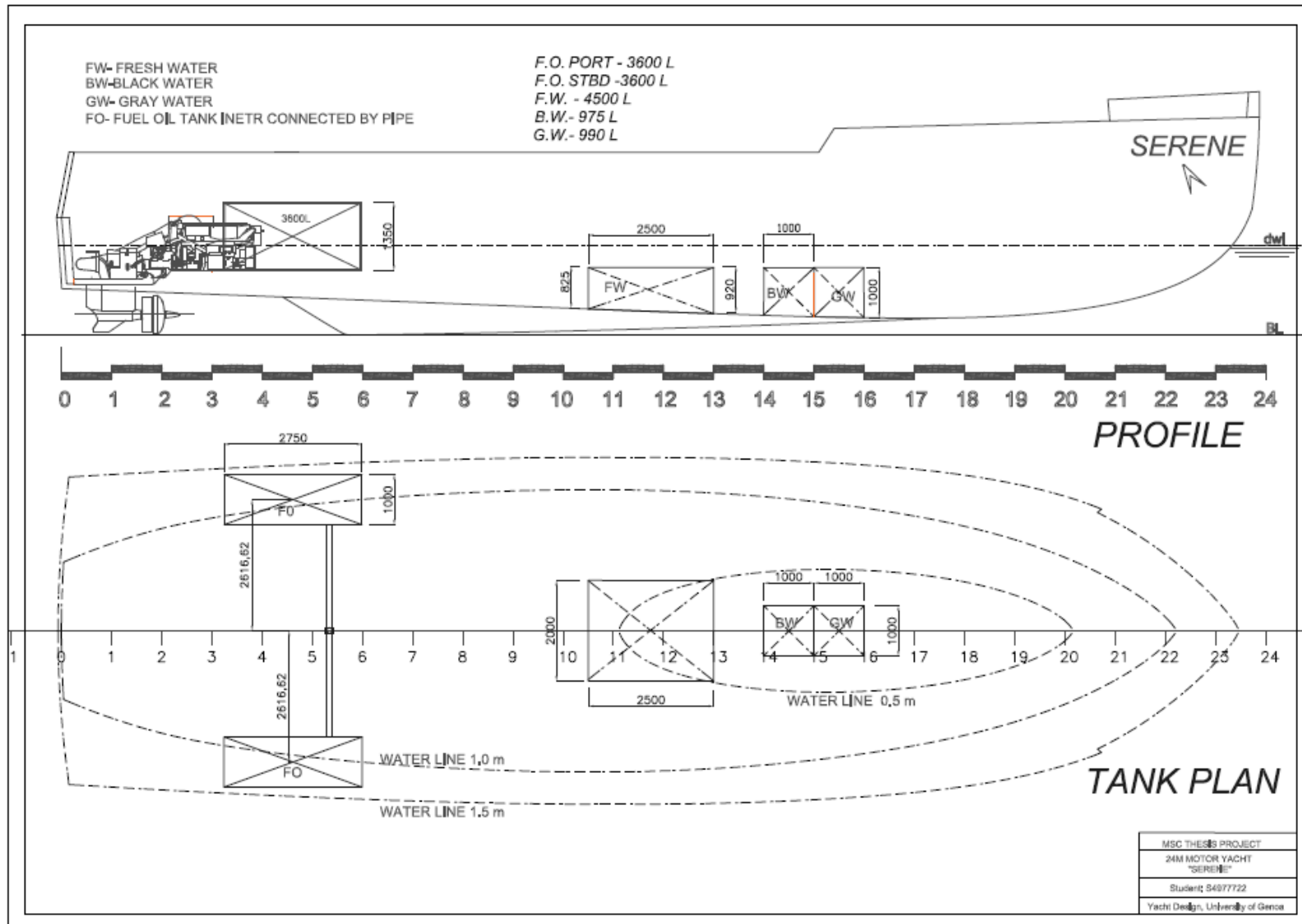

Table 2. Summary of free surface correction

Free Surface Correction:						Specific Gravity	i	x	ρ	=
						ρ	i	x	ρ	=
FO (p)		L1	=	2.75	m					
		w1	=	1	m					
		d1	=	2.616	m					
		i	=	19.04867	m ⁴	0.860				16.382
FO (s)		L1	=	2.75	m					
		w1	=	1	m					
		d1	=	2.616	m					
		i	=	19.04867	m ⁴	0.860				16.382
FW		L1	=	2	m					
		w1	=	1	m					
		i	=	0.166667	m ⁴	1.000				0.1667
BW		L1	=	1	m					
		w1	=	1	m					
		i	=	0.0833333	m ⁴	1.000				0.0833
GW		L1	=	1	m					
		w1	=	1	m					
		i	=	0.0833333	m ⁴	1.000				0.0833
						Σ	i	x	ρ	33.097
Σ	i	x	ρ	33.09705						
				Displacement (MT)		Free surface Correction (m)		$\Sigma(i x \rho) / \Delta$		
						ϵ_T				
Condition 1				116.77		0.283				
Condition 2				110.67		0.299				
Condition 3				106.012		0.312				

Table 3. GZ Calculation Condition 1

<u>GZ CALCULATION USING CROSS CURVES (For 100% loading Voyage)</u>												
<i>Displacement of the ship</i>			=	116.77	<i>Tonnes</i>		<i>VCG</i>			=	2.872	<i>m</i>
<i>Free surface correction</i>			=	0.2873	<i>M</i>							
<i>Corrected VCG (KGc)</i>			=	3.159	<i>Meters (Considering Free Surface Moment)</i>							
<i>Righting Lever :</i>												
GZ			=	KN – KG Sin Ø		<u>KG from manual calculation</u>						
<i>Where</i>								<u>KN from Cross curve</u>				
<i>KN</i>	=		<i>Cross Curve Ordinate in Meters</i>									
<i>A</i>	=		<i>Angle of Heel</i>									
Heeling Angle, A	5°	10°	20°	30°	40°	50°	60°	70°	80°			
<i>SinA</i>	0.09	0.1736	0.3420	0.5000	0.6428	0.7660	0.8660	0.9397	0.9848			
<i>KGc x SinA (m)</i>	0.28	0.5486	1.0805	1.5797	2.0308	2.4202	2.7360	2.9688	3.1113			
<i>KN (m)</i>	0.46	0.8957	1.6149	2.1657	2.5825	2.8527	2.9417	2.8847	2.7145			
GZ (m)	0.18	0.3471	0.5344	0.5861	0.5517	0.4325	0.2057	- 0.0841	- 0.3968			
<i>Then by using the above GZ values, the Static Stability Curve has been drawn</i>												

Table 4.GZ Calculation Condition 2

<u>GZ CALCULATION USING CROSS CURVES (Voyage- 50% Loading)</u>										
<i>Displacement of the ship</i>	=	110.67	Tonnes	VCG	=	2.874	m			
<i>Free surface Correction</i>	=	0.2991	M							
<i>Corrected VCG (KGc)</i>	=	3.173	<i>Meters (Considering Free Surface Moment)</i>							
<u>Loading Condition 2: 50% Consumables</u>										
<i>Righting Lever :</i>										
$GZ = KN - KG \sin \theta$				<u>KG from manual calculation</u>						
<i>Where</i>				<u>KN from Cross curve</u>						
<i>KN</i>	=	<i>Cross Curve Ordinate in Meters</i>								
<i>A</i>	=	<i>Angle of Heel</i>								
Heeling Angle, A	5°	10°	20°	30°	40°	50°	60°	70°	80°	
<i>SinA</i>	0.09	0.1736	0.3420	0.5000	0.6428	0.7660	0.8660	0.9397	0.9848	
<i>KGc x SinA (m)</i>	0.28	0.5510	1.0853	1.5865	2.0396	2.4307	2.7480	2.9817	3.1249	
<i>KN (m)</i>	0.48	0.9140	1.6360	2.1810	2.591	2.8690	2.9600	2.9150	2.7277	
GZ (m)	0.20	0.3630	0.5507	0.5945	0.5514	0.4383	0.2120	-0.0667	-0.3972	
<i>Then by using the above GZ values, the Static Stability Curve has been drawn:</i>										

Table 5. GZ Calculation Condition 3

<u>GZ CALCULATION USING CROSS CURVES (Arrival -10%)</u>										
<i>Displacement of the ship</i>		=	106.012	Tonnes	VCG	=	2.898	m		
<i>Free surface Correction</i>		=	0.3122	M						
<i>Corrected VCG (KGc)</i>		=	3.210	Meters (Considering Free Surface Moment)						
<i>Righting Lever :</i>					Loading Condition 3 : 10% Consumables					
$GZ = KN - KG \sin \theta$					<u>KG from manual calculation</u>					
<i>Where</i>					<u>KN from Cross curve</u>					
<i>KN</i>	=	<i>Cross Curve Ordinate in Meters</i>								
<i>A</i>	=	<i>Angle of Heel</i>								
Heeling Angle, A	5°	10°	20°	30°	40°	50°	60°	70°	80°	
<i>SinA</i>	0.09	0.1736	0.3420	0.5000	0.6428	0.7660	0.8660	0.9397	0.9848	
<i>KGc x SinA (m)</i>	0.28	0.5574	1.0980	1.6051	2.0635	2.4592	2.7801	3.0166	3.1614	
<i>KN (m)</i>	0.49	0.9290	1.6410	2.1940	2.5970	2.8800	2.9730	2.9150	2.7380	
GZ (m)	0.21	0.3715	0.5430	0.5889	0.5335	0.4208	0.1928	-0.1016	-0.4235	
<i>Then by using the above GZ values, the Static Stability Curve has been drawn:</i>										

Table 6. Tangent of Trim angle

	$\tan \phi_L$	=	(LCG-LCB)/(BM _L +VCB-VCG)			
Condition:	-0.01	≤	$\tan \phi_L$	≤	0	
	Reference from base and from fr.0					
Displacement in MT	Hydrostatic values					
	LCB	LCG-LCB	KM _L	VCB	KM _L -VCB	$\tan \phi_L$
106.63	10.878		49.98	1.151		
105.23	10.883		49.56	1.156		
m	-0.00357143		0.3	-0.00357		
m*(x-x1)	-0.00279286		0.2346	-0.00279		
106.012	10.880	-0.611	49.795	1.153	48.641	-0.0130
117.95	10.85		45.97	1.202		
116.53	10.852		46.31	1.196		
m	-0.00140845		-0.2394366	0.004225		
m*(x-x1)	-0.00033803		-0.0574648	0.001014		
116.77	10.852	-0.837	46.253	1.197	45.056	-0.019
110.87	10.866		48.1	1.173		
109.45	10.87		48.58	1.168		
m	-0.0028169	0	-0.3380282	0.003521	0	0
m*(x-x1)	-0.00343662	0	0.24120452	0.000849		
110.67	10.86656338	0.71356338	48.8212045	1.168849	47.65236	-0.0155
Summary						
	Displacement (MT)		$\tan \phi_L$			
Condition 1: 100% Consumables	116.77		-0.019	Pass		
Condition 2: 50% Consumables	110.67		-0.0155	Pass		
Condition 3: 10% Consumables	106.012		-0.0130	Pass		

Note: Trim angle to be further checked in future design steps.

Table 7. Metacentric height

	$GM^T = BM^T + VCB - VCG$	€	€	= Free surface correction		
			GM^T	\geq	0.15	m
Unit	M	m		m	m	m
	KM^T	VCB	BM^T	VCG	€	GM^T
	106.63	5.642				
	105.23	5.649				
m		-0.005				
m*(x-x1)		-0.00391				
	106.012	5.645	1.153	4.492	2.898	0.312
	110.87	5.491				
	109.45	5.534				
m		-0.03028169				
m*(x-x1)		-0.03694366				
	110.67	5.497	1.169	4.328	2.874	0.299
	117.95	5.308				
	116.53	5.33				
m		-0.01549296				
m*(x-x1)		-0.00371831				
	116.77	5.326	1.197	4.129	2.872	0.283

During Arrival condition vertical metacentric height found maximum and the value is 2.435 m

5.4 GZ curves for three conditions

GZ curves were drawn for each loading condition.

Figure 18. GZ Curve for 100% loading, Voyage

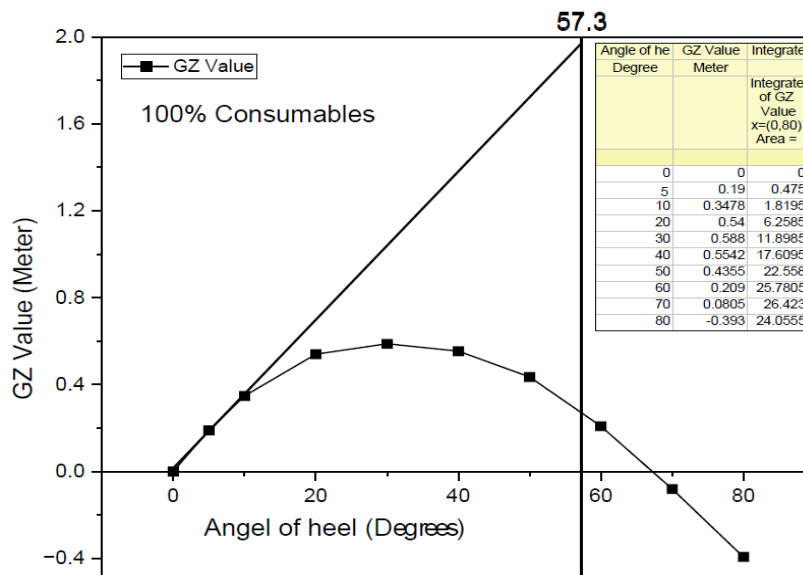

Figure 19. GZ Curve for 50% Loading, Mid voyage

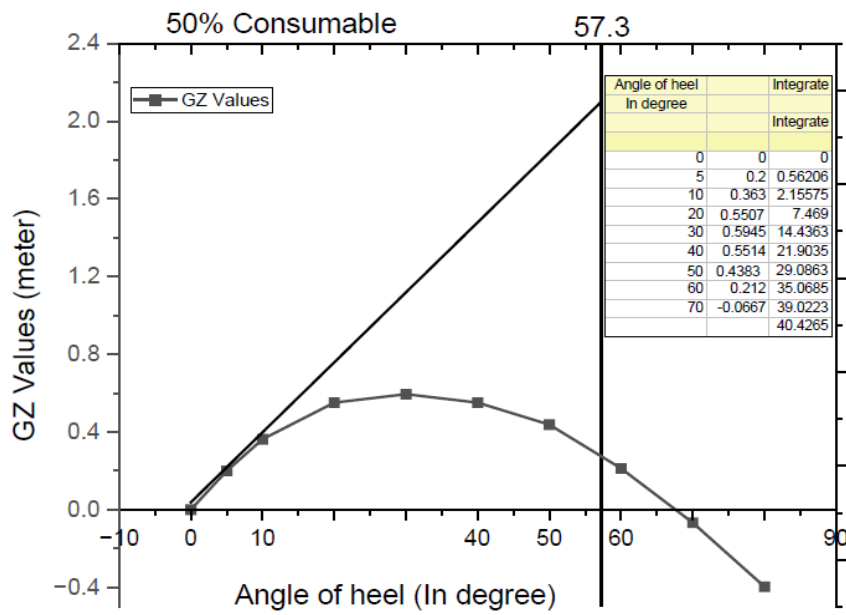
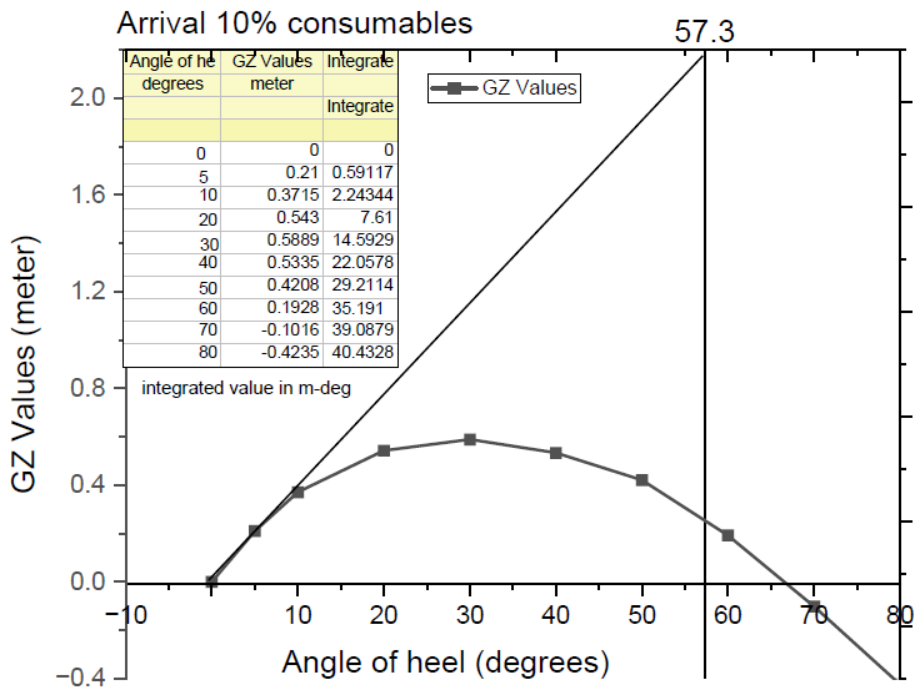

Figure 20. GZ Curve for 10% Loading, Arrival



5.4.1 Area under GZ Curve and Intact Stability Criteria

Criteria under GZ Curve	Condition 1	Condition 2	Condition 3	Results
The area under the curve up to 30 deg > 0.055 m-rad	0.207	0.252	0.255	Satisfactory
Area under the curve up to 40 deg > 0.03 m-rad	0.307	0.382	0.385	Satisfactory
Area under the curve bet 30 deg to 40 deg > 0.03 m-rad	0.10	0.13	0.13	Satisfactory
Maximum GZ to be at least 0.20 m at 30 degrees or above	0.588	0.594	0.589	Satisfactory
Maximum GZ to be at an angle > 25 degrees	30 deg	30 deg	30 deg	Satisfactory

6. Structural Scantlings

For structural scantlings “RINA RULES FOR PLEASURE Yachts” has been followed. Since the vessel is less than 24-meter length there are no special rules applicable to structural scantlings. However, from safety point of view scantling verified based on classification requirements.

6.1 Scantling Calculation

Scantling length $L = 23.36\text{ m}$, Maximum breadth, $B = 6.95\text{ m}$, Full load Draft $T = 1.78\text{ m}$
 For construction of structural material of boat Aluminium alloy grade 5083, H111 has been selected with yield strength $R_{p0.2} = 110\text{ N/mm}^2$ [reference – Part B, Chapter 3, Sec 1, Art 1.1.1]
 $T =$ Draft of the Yacht in meter, $s =$ ordinary stiffeners spacing in meter

6.1.1 Displacement Yacht

Reference: Part B, Ch 1, Sec 5, Art 2.2.1.
 Displacement Yacht $V/L^{0.5} \leq 4$
 $V = 12\text{ Knots}$, $L = 23.36\text{ m}$, $V/L^{0.5} = 2.48$.
 SERENE is a displacement yacht

6.1.2 Block Coefficient

Reference: Part B, Ch 1, Sec 5, Art 2.3.1
 Block Coefficient $C_B = (\Delta / 1.025 * L * B * T)$
 For scantling calculation displacement has been considered from Software generated value approximate rounded value 130 MT
 $C_B = 0.439$

6.1.3 Acceleration

Reference: Part B, Ch 1, Sec 5, Art 3.1.1

Vertical Acceleration at LCG, $a_{cg} = S * (V/L^{0.5}) = 0.712 \text{ m/s}^2$

$S = 0.65 C_F = 0.65 * 0.442 = 0.2873$

$C_F = 0.2 + [0.6 / (V/L^{0.5})] \geq 0.32$
 $= 0.442$

6.1.4 Design pressure bottom plate and side shell

Reference: Part B, Ch 1, Sec 5, Art 5.3.2 and 5.4.2

$P_1 = 0.24 * L^{0.5} * (1 - h_0/2T) + 10 * (h_0 + a * L)$

Considering $a = 0.036$, $T = 1.78$, $L = 23.36$, $h_0 = 1.78$

$P_1 = 26.79 \text{ KN/m}^2$ for bottom plate and structure

$P_1 = 66.25 * (a + 0.024) * (0.15L - h_0) = 4.11174 \text{ KN/m}^2$ for side structure and plates

6.1.5 Material Factor

Reference: Part B, Ch 3, Sec 2, Art 1.6.1

$\eta = \text{Alloys without work - hardening treatment series 5000 in annealed condition 0 or annealed flattened condition H111} = 1$

Material factor $K = 110 / (\eta * R_{p0.2}) = 1$

6.1.6 Minimum Thickness requirement for plates

Reference: RINA Pleasure yacht - Part B, Ch 3, Sec 1, Art. 6.1

Member	Scantling	Rules Requirement	Actual
Keel, Bottom Plating	$t_1 = 1.75 * L^{1/3} * K^{0.5}$	5 mm	Keel 8 mm, Bottom 6 mm
Side Plating	$t_2 = 1.50 * L^{1/3} * K^{0.5}$	4.29 mm	6 mm
Open Strength Deck Plating	$t_3 = 1.50 * L^{1/3} * K^{0.5}$	4.29 mm	6 mm
Lower and enclosed Deck Plating	$t_4 = t_3 - 0.5$	3.79 mm	6 mm
1 ST Tier Super struc Front Bhd	$t_5 = t_1$	5 mm	5 mm
Super structure Bulkhead	$t_6 = t_5 - 1.5$	3.5 mm	5 mm
Watertight Subdivision Bhd	$t_7 = t_2 - 0.5$	3.79	6 mm
Tank Bulkhead	$t_8 = t_2$	4.29 mm	6 mm
Center Girder	$t_9 = 2.3 * L^{1/3} * K^{0.5}$	6.58 mm	14 mm
Floors and Side Girders	$t_{10} = 1.70 * L^{1/3} * K^{0.5}$	4.86 mm	10 mm

6.1.7 Primary supporting members

Reference: Part B, Ch 3, Sec 1, Art. 7.1

$A_s = \text{Area of attached plating in cm}^2 = 10c * b_F * t_s$

$S_L = \text{Maximum overall length of the girder} = 6 \text{ meter}$

$b_F = \text{Actual width of load bearing plating in meter} = 3.475 \text{ m}$

$$S_L / b_F = 1.726 < 8$$

$$c = 0.25 * (S_L / b_F) - 0.016 * (S_L / b_F)^2 = 0.38384$$

$A_s = 80 \text{ cm}^2$, $t_s = \text{mean thickness of attached plating} = 6 \text{ mm}$

6.1.8 Section Modulus Primary member

Reference: Part B, Ch 3, Sec 1, Art. 7.4

The section Modulus

$$W_T = (A_P * d_a / 10) + (t_s * d_a^2 / 6000) * [1 + \{200 * (A_s - A_P)\} / \{200 A_s + t_a * d_a\}] \text{ in cm}^3$$

$A_s = 80 \text{ cm}^2$

$t_s = \text{Mean thickness of attached plating} = 6 \text{ mm}$

$t_a = \text{Web Thickness in mm} = 8 \text{ mm}$

$d_a = \text{Web depth in built section in mm} = 150 \text{ mm for deck girder, } 200 \text{ mm for bottom girder}$

$A_P = \text{Area of web plate} = 1.5 \text{ cm} * 0.8 \text{ cm} = 12 \text{ cm}^2$

$d_a = \text{web depth } 150 \text{ mm}$

$t_s = \text{mean thickness of attached plate} = 6 \text{ mm}$

$t_a = \text{Web thickness in mm} = 8 \text{ mm}$

$W_T = 252 \text{ cm}^3$

Applicable to Centre line girder

		Size (mm)	
		Length/Thickness	Thickness / Depth
Plate	3.475	6.0	
Web/Plate	14	200	
Face Plate	100	14	
$SM_{\text{required}} (\text{cm}^3)$	Proposed Size	$SM_{\text{proposed}} (\text{cm}^3)$	Status
252.00	200x14 w + 100x14 F.B.	258.69	Pass

6.1.9 Keel Plate Length and Thickness

Reference- Part B, Ch 3, Sec 5, Art 2

$b_{CH} = 4.5 * L + 600 = 705.12 \text{ mm}$, Actual more than 6000 mm

Thickness to be greater than 2mm from adjacent bottom plate.

Bottom plate 6mm, Keel Plate 8 mm

6.1.10 Bottom Side Girder

Reference - Part B, Ch 3, Sec 6, Art 3.3.1

Section modulus, $Z = K_1 * b_{PC} * S * K * P$ in cm^3

$b_{PC} = 1.1 \text{ m}$, $P = 26.79 \text{ KN/m}^2$, $S = 6.0 \text{ m}$, $K = 1.0$, $K_1 = 1.6$

$Z = 282 \text{ cm}^3$

Figure 21. Actual Bottom centre girder Scantling

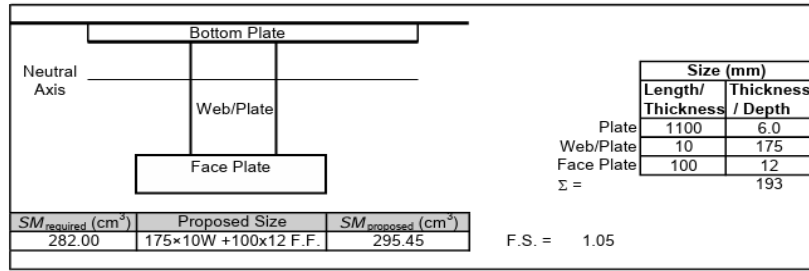

6.1.11 Bottom Longitudinals

Reference- Part B, Ch 3, Sec 6, Art 3.1

Section Modulus, $Z = K_1 * s * S * K * P$ in cm³

$K_1 = 1.6$, $s =$ spacing 0.55 m, $S =$ Span length = 1.0 m, $K =$ Material Factor = 1.0

$Z = 23.57$ cm³

Figure 22. Actual Scantling calculation of Bottom Longitudinal

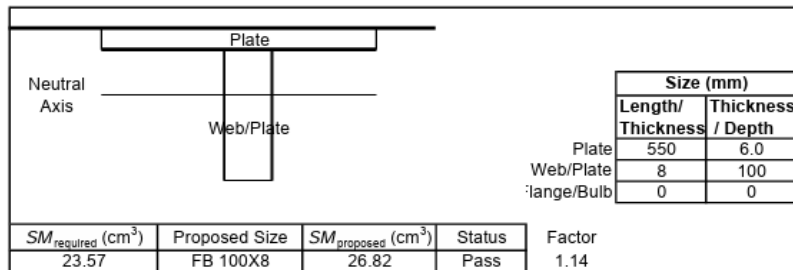

6.1.12 Side Transverse Frame

Reference- Part B, Ch 3, Sec 8, Art 3.1.1

Side Transverse Frame section modulus, $Z = K_1 * s * S^2 * K * p$ (cm³)

$K_1 = 1.27$, $S = 6.0$ m, $P = 26.79$ KN/m², $K = 1.0$, $s = 1.0$ m, $S = 1.65$ m

$Z = 92.628$ cm³

Figure 23. Actual Scantling Calculation of side transverse Frame

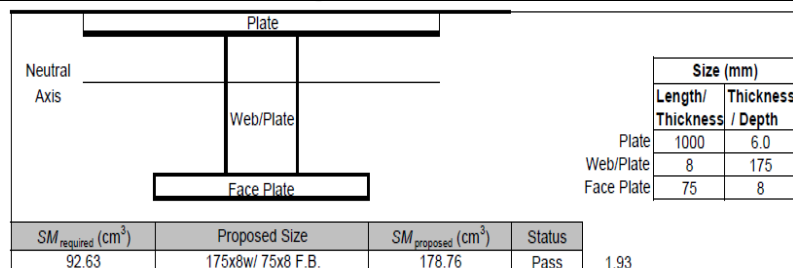

6.1.13 Side Longitudinal

Reference- Part B, Ch 3, Sec 8, Art 3.2.1

Side longitudinal section modulus, $Z = K_1 * s * S^2 * K * p$ (cm³)

$K_1 = 1.6$, $S = 1.0$ m, $P = 26.79$ KN/m², $K = 1.0$, $s =$ spacing 0.550 m, $S =$ span length 1.0 m

$Z = 23.57$ cm³

Figure 24. Actual scantling of side longitudinal

		Size (mm)		Factor	
		Length/ Thickness	Thickness / Depth		
Neutral Axis	Web/Plate	Plate	550	6.0	1.14
		Web/Plate	8	100	
		Flange/Bulb	0	0	
$SM_{required}$ (cm ³)	Proposed Size	$SM_{proposed}$ (cm ³)	Status		
23.57	FB 100X8	26.82	Pass		

6.1.14 Deck Longitudinal

Reference- Part B, Ch 3, Sec 9, Art 4.1.1

Ordinary longitudinal section modulus, $Z = 14 * C_1 * s * S^2 * K * h$ (cm³)

$C_1 = 1.44$, $S =$ span 1.0 m, $P = 26.79$ KN/m², $K = 1.0$, $s =$ spacing 0.550 m,

$Z = 23.57$ cm³

Figure 25. Actual scantling of deck longitudinal

		Size (mm)		Factor	
		Length/ Thickness	Thickness / Depth		
Neutral Axis	Web/Plate	Plate	550	6.0	1.14
		Web/Plate	8	100	
		Flange/Bulb	0	0	
$SM_{required}$ (cm ³)	Proposed Size	$SM_{proposed}$ (cm ³)	Status		
23.57	FB 100X8	26.82	Pass		

6.2 Summary of Structural Scantling

No	Scantling Member	Scantling
1	Keel, Bottom Plating	Keel 8 mm, Bottom 6 mm
2	Side Plating	6 mm
3	Open Strength Deck Plating	6 mm
4	Lower and enclosed Deck Plating	6 mm
5	1 ST Tier Super struc Front Bhd	5 mm
6	Super structure Bulkhead	5 mm
7	Watertight Subdivision Bhd	6 mm
8	Tank Bulkhead	6 mm
9	Center Girder	14 mm
10	Floors and Side Girders	10 mm
11	Side, deck and bottom longitudinal	100x8 FB
12	Bottom Girder	Center – 200x14w/100x14 FB, Side-175x10w/100x12FB
13	Transverse web Frame	Floor, side and deck -175x8 w/75x8FB
14	Deck Center Girder	200x14w/100x14 FB
15	Bridge Deck plating	4 mm

7. Drawings

- General Arrangement
- Lines Plan
- Section
- Tank Capacity Plan

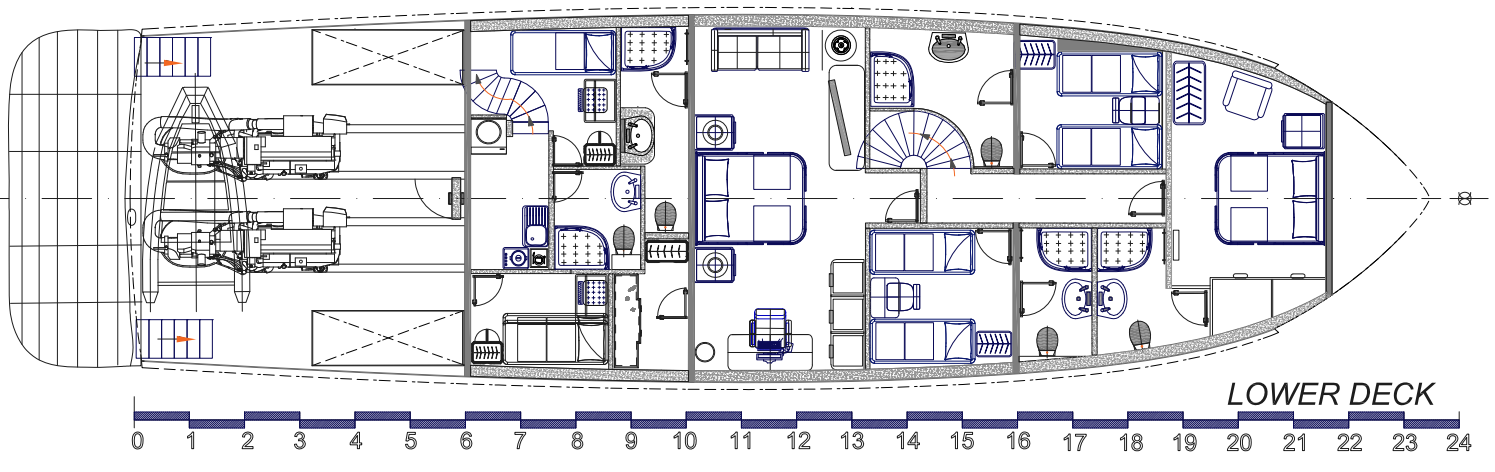
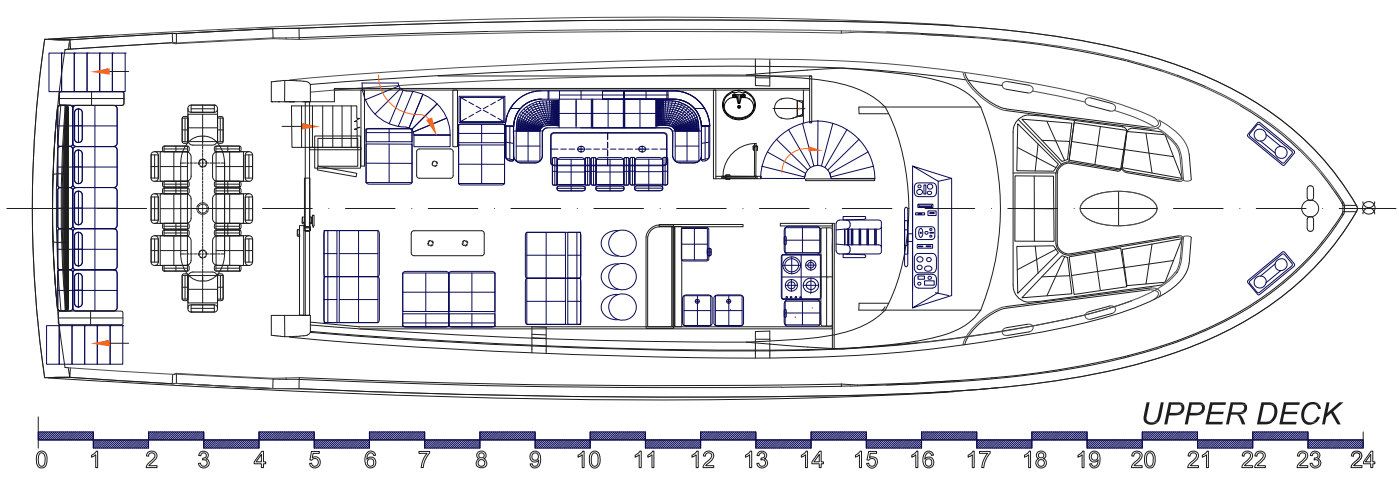
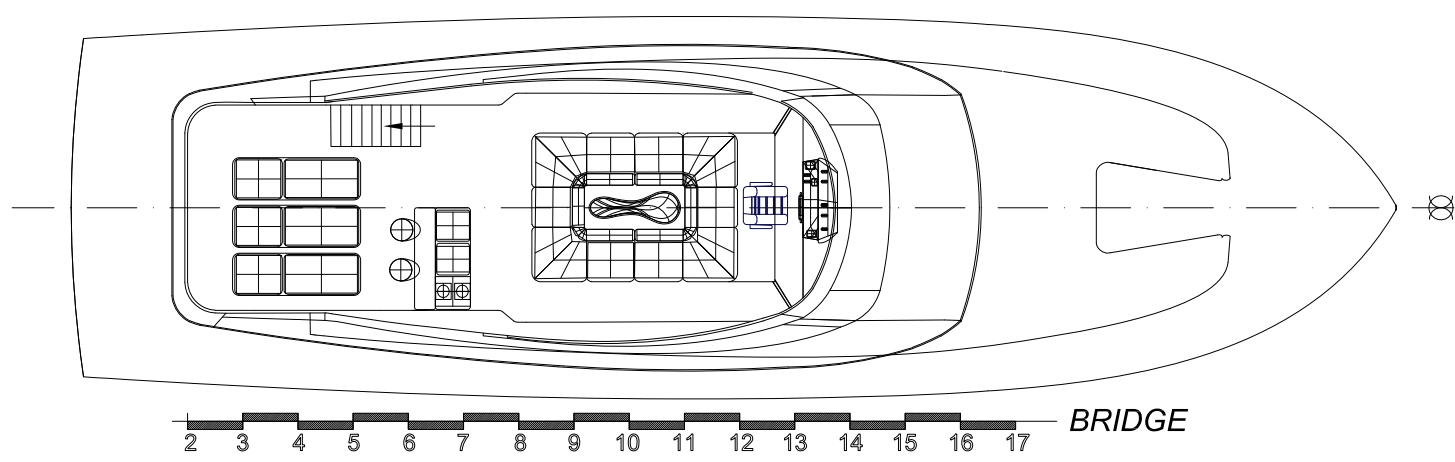
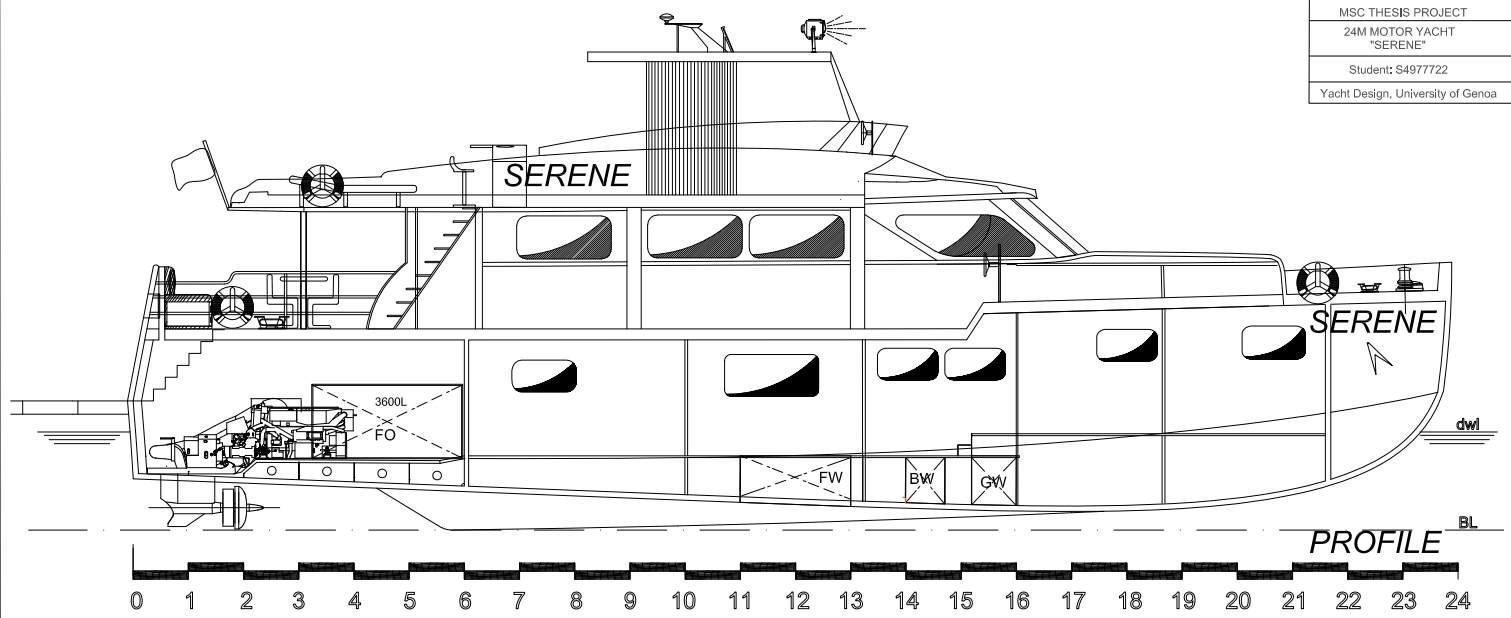

LINES PLAN

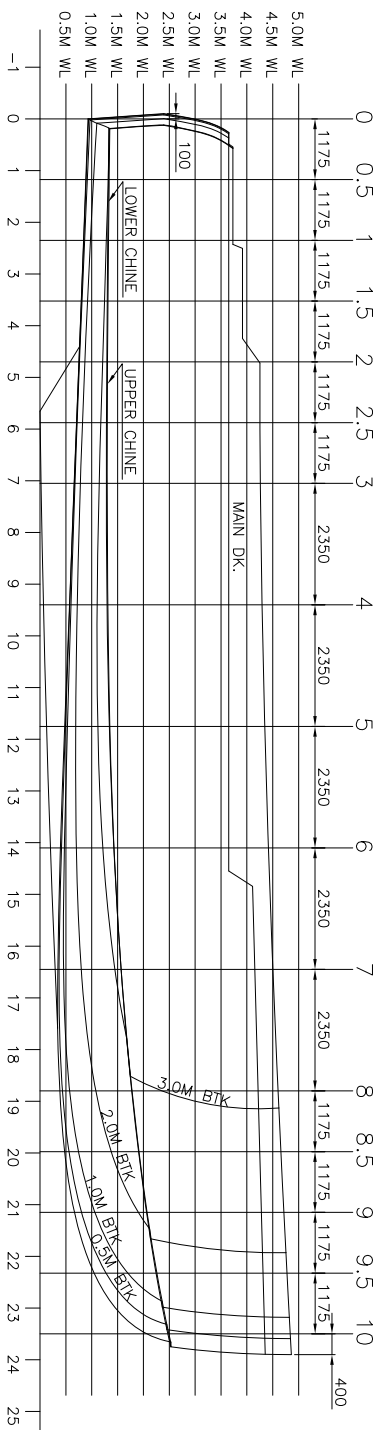

PROFILE PLAN

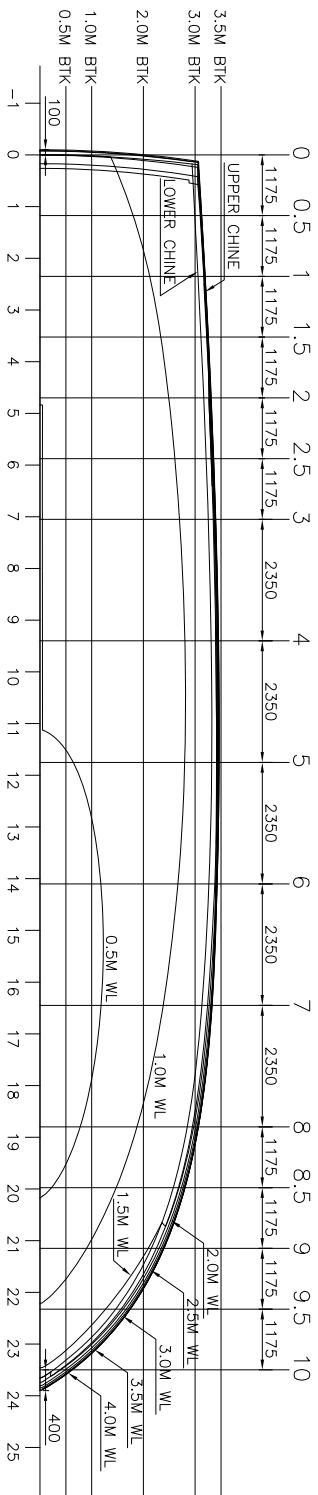

HALF BREADTH PLAN

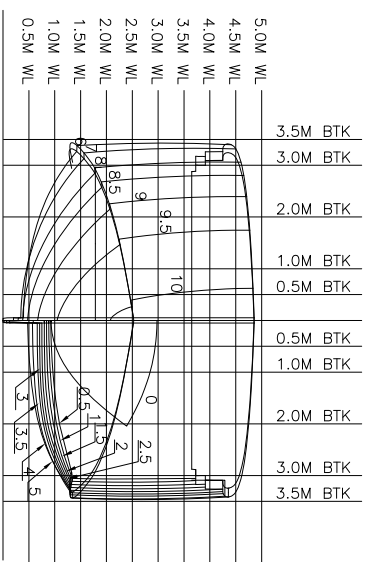

BODY PLAN

Principal particulars

Length oa = 24.00m
 Length bp = 23.36m
 Breadth = 6.95m
 Depth = 3.65m
 Draft = 1.78m
 Frame spacing 1000 mm

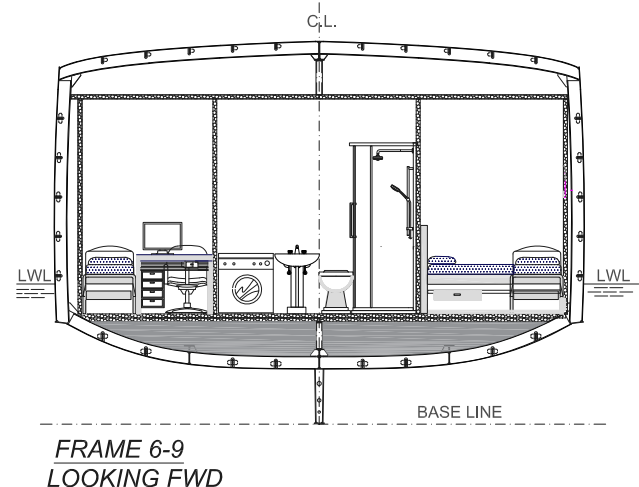
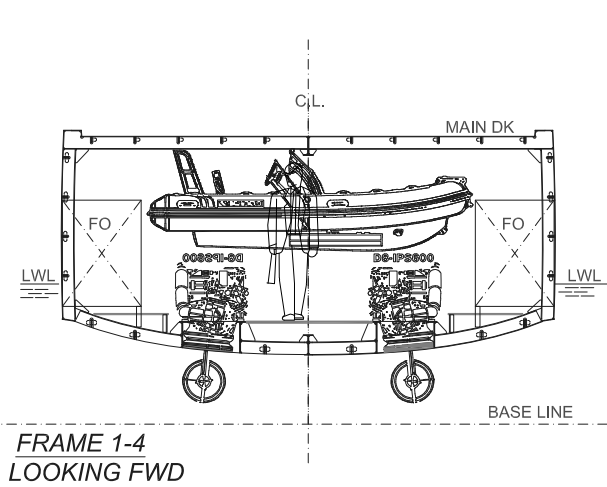
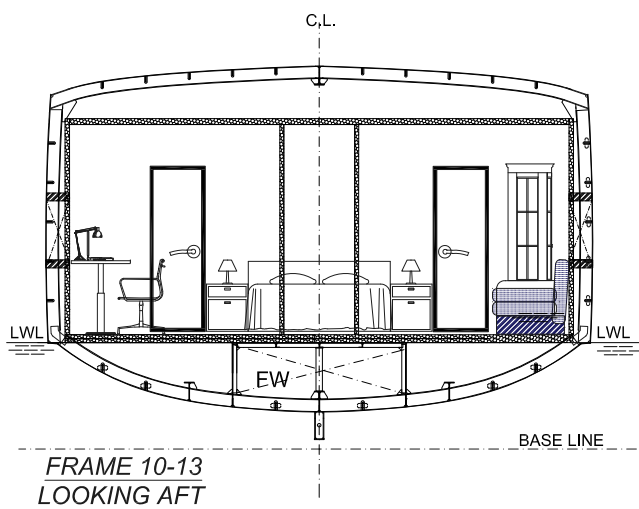
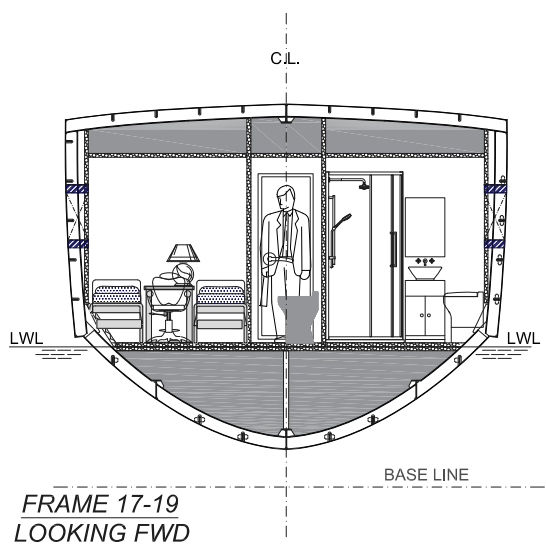
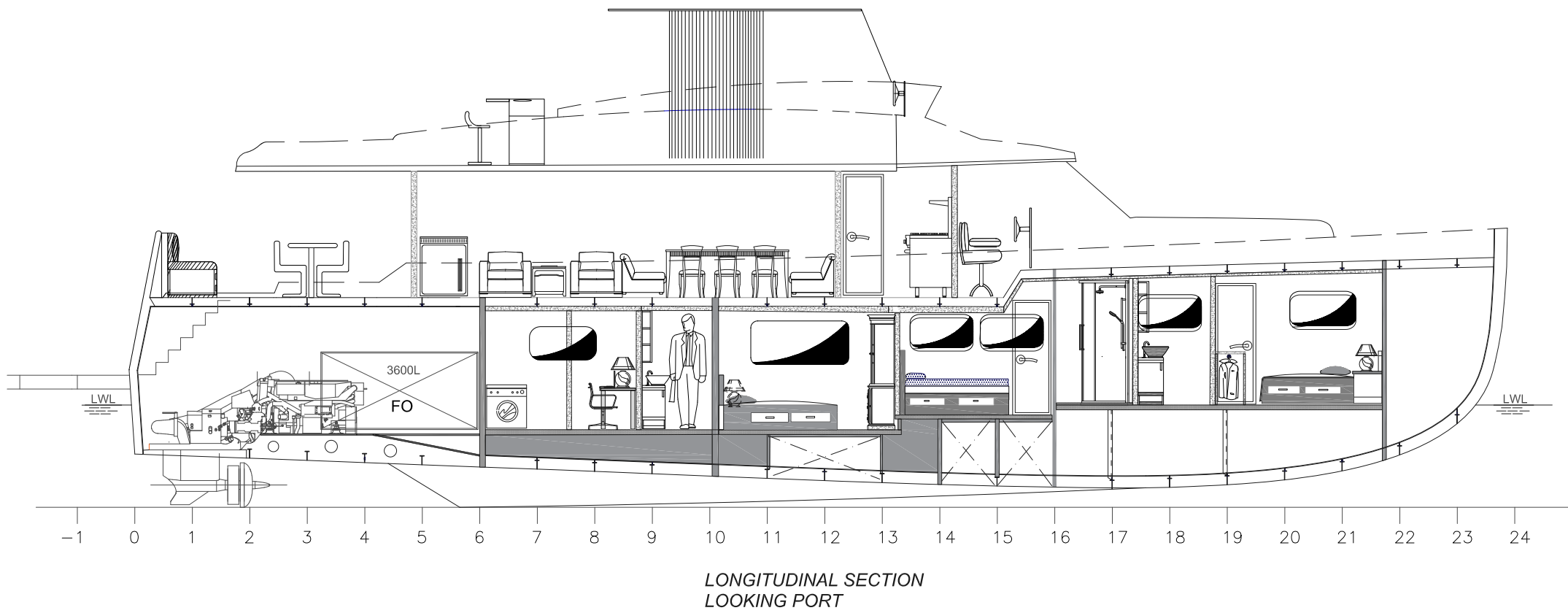
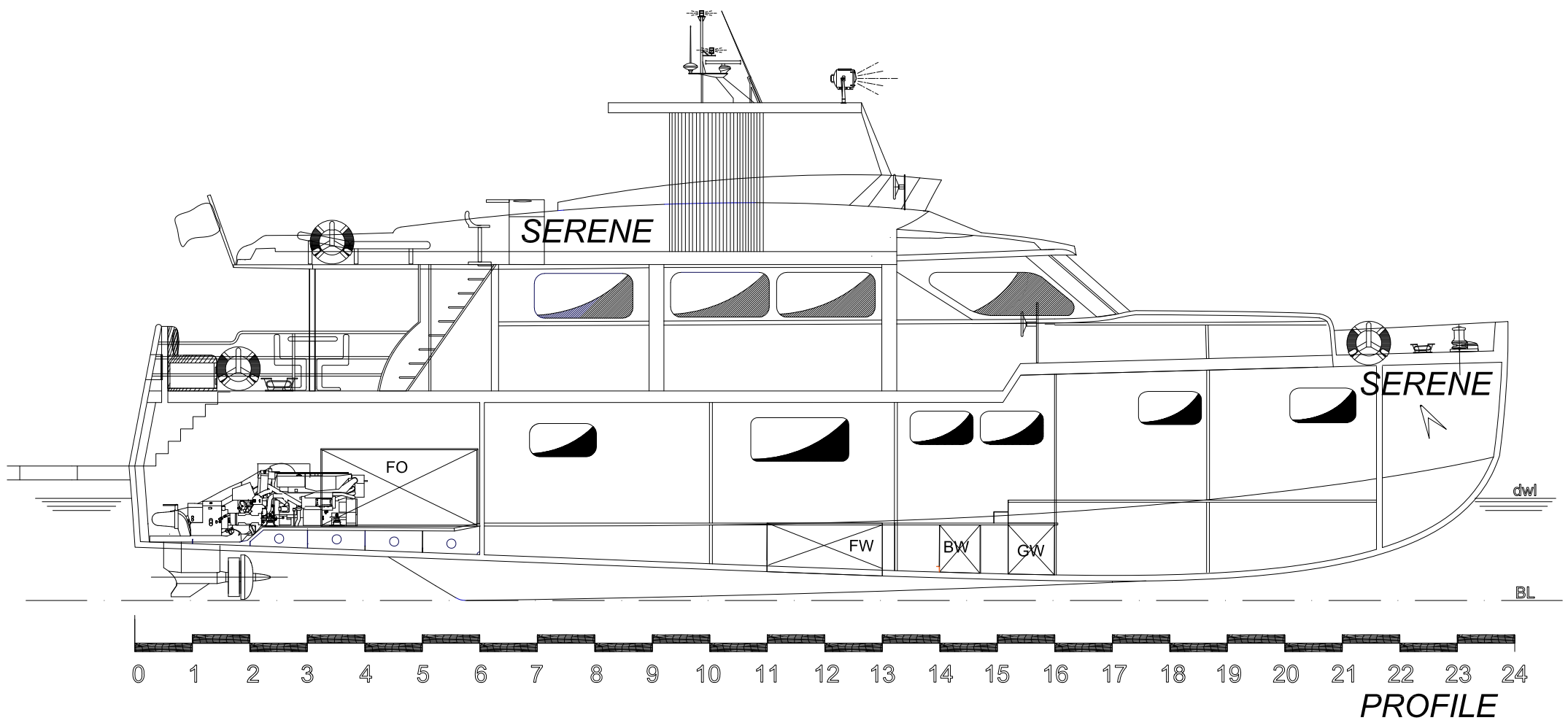

MSC THESIS PROJECT
24M MOTOR YACHT "SERENE"
Student: S4977722
Yacht Design, University of Genoa

FW- FRESH WATER
 BW- BLACK WATER
 GW- GRAY WATER
 FO- FUEL OIL TANK INETR CONNECTED BY PIPE

F.O. PORT - 3600 L
 F.O. STBD - 3600 L
 F.W. - 4500 L
 B.W. - 975 L
 G.W. - 990 L

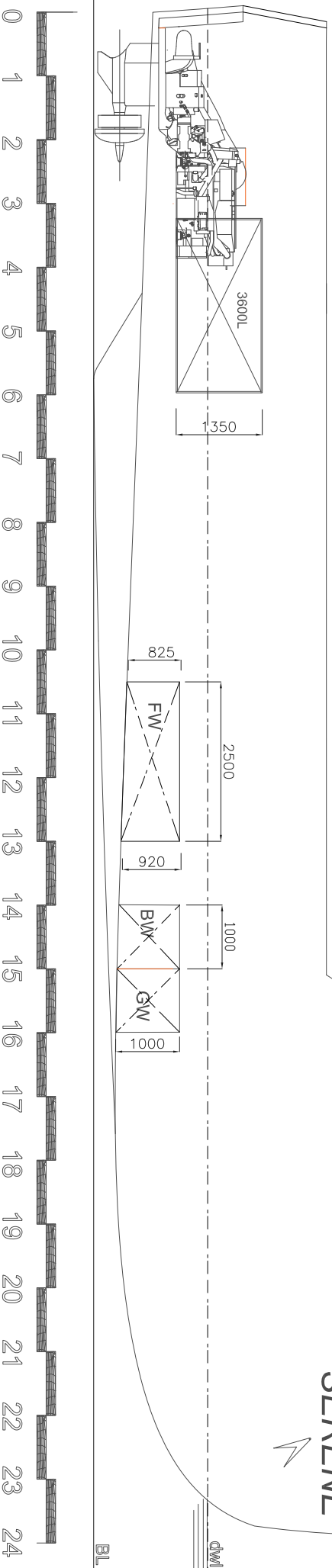

PROFILE

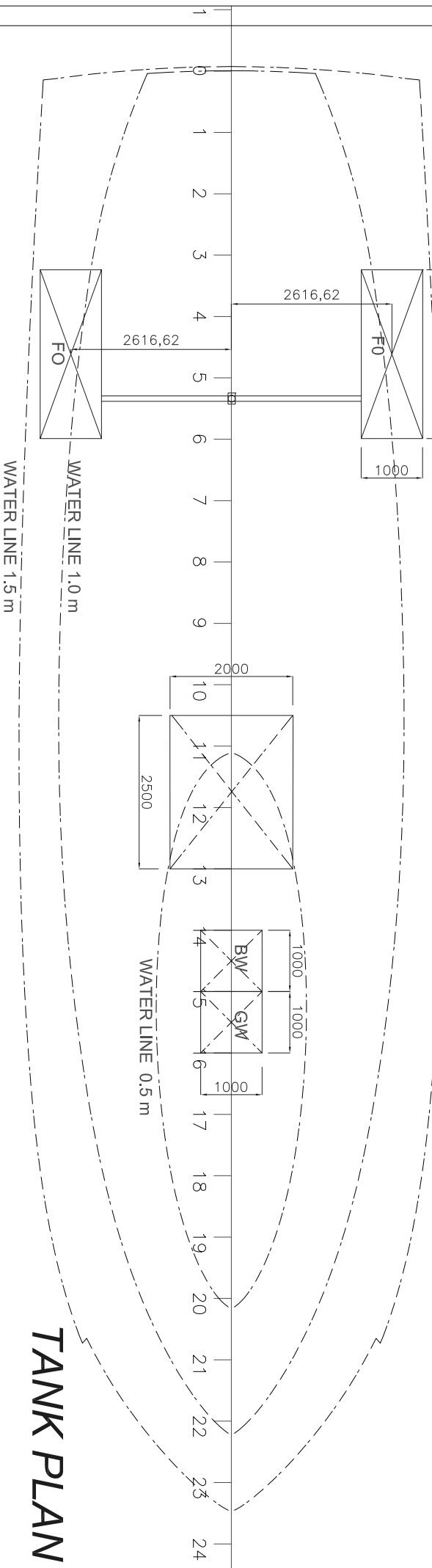

TANK PLAN

MSC THESIS PROJECT
24M MOTOR YACHT
"SERENE"
Student: S4977722
Yacht Design, University of Genoa

8. Resistance and Power Prediction

To select proper engine power, the resistance prediction of the created hull model has been uploaded to Maxsurf. Since the yacht is a displacement hull, Holtrop and Mennen method has been used in alignment with *An approximation power prediction method, Holtrop and Mennen, 1982*

According to this method the total ship resistance has been represented with the following formula and components,

$$R_{\text{total}} = R_F (1+k_1) + R_{\text{APP}} + R_W + R_B + R_{\text{TR}} + R_A$$

Where R_F is the frictional resistance that is mentioned in ITTC '57, R_{APP} is the appendage resistance, R_W is the wave resistance, R_B is additional pressure resistance of bulbous bow, R_{TR} is the additional resistance due to the immersed transom stern and R_A is the model ship correlation resistance. Because of the absence of bulbous bow and immersed transom, these two components are not considered.

Figure 26: 3D hull model import to Maxsurf

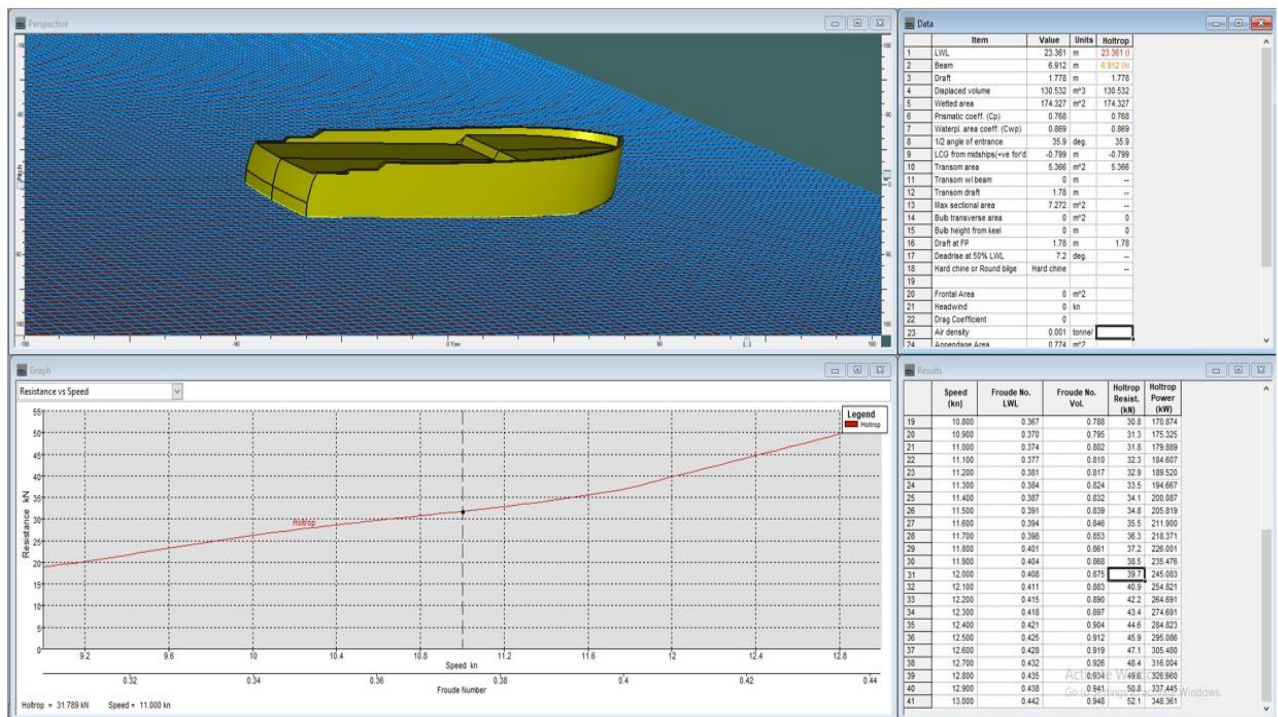

Table 8. Basic information on yacht and Maxsurf results for Resistance.

MAXSURF RESULTS FOR RESISTANCE						
	Item description			Value	Holtrop	
1	Length Over all	LOA		24	24.000	M
2	Length Water Line	LWL		23.361	23.361(Low)	M
3	Length Between Perpendiculars	L _{PP}		23.361	23.360	M
4	Breadth Moulded	B	=	6.912	6.612 (High)	M
5	Loaded Draft (moulded)	T		1.778	1.778	M
6	Displacement volume			130.532	133.690	M ³
7	Longitudinal Center of Buoyancy	L _{CB}	=	-0.060	-0.060	% aft of 1/2 L
8	Block Coefficient	C _b		0.453	0.453	
9	Midship Section Coefficient	C _M		0.594	0.594	
10	Water plane area coefficient	C _{WP}		0.869	0.869	
11	Prismatic Coefficient	C _P		0.768	0.768	
12	Half Angle of Entrance	i _E	=		38.000	Degrees
13	Wetted Area			174.327	174.327	M ²
14	1/2 angle of entrance			35.9	35.900	degrees
15	LCG from midships (+ve for'd)			-0.799	-0.799	M
16	Transom Area			5.366	5.366	M ²
17	Transom draft			1.78	-	M
18	Transom wl beam			0	0.000	M
19	Max sectional area			7.272	-	M ²
20	Bulb Transverse area			0	0.000	M ²
21	Bulb height from Keel			0	0.000	M
22	Draft at FP			1.78	1.780	M
23	Deadrise at 50% LWL			7.2	-	deg
24	Hard chine or Round Bilge			Hard Chine	-	
25	Functional Area			0	-	M ²
26	Headwind			0		Kn
27	Drag coefficient			0		
28	Air density			0.001		tonne/m
29	Appendage Area			0.774		M ²
30	Nominal App. Length			0		M2
31	Appendage Factor			1		
32	Correlation allowance			0.0004	Calculated	
33	Kinematic viscosity			0.000001188		M ² /s
34	Water density			1.026		tonne/m

Table 9: Maxsurf results with Holtrop resistance

MAXSURF Result with HOLTROP					
No	Speed (Knots)	Froude No LWL	Froude No Vol	Holtrop Resistance (KN)	Holtrop Effective Power (KW)
1	9	0.306	0.656	18.9	87.344
2	9.1	0.309	0.664	19.5	91.43
3	9.2	0.313	0.671	20.2	95.755
4	9.3	0.316	0.678	21	100.3
5	9.4	0.319	0.686	21.7	105.034
6	9.5	0.323	0.693	22.5	109.917
7	9.6	0.326	0.7	23.3	114.9
8	9.7	0.33	0.708	24	119.932
9	9.8	0.333	0.715	24.8	124.963
10	9.9	0.336	0.722	25.5	129.948
11	10	0.34	0.729	26.2	134.853
12	10.1	0.343	0.737	26.9	139.657
13	10.2	0.347	0.744	27.5	144.34
14	10.3	0.35	0.751	28.1	148.914
15	10.4	0.353	0.759	28.7	153.39
16	10.5	0.357	0.766	29.2	157.79
17	10.6	0.36	0.773	29.7	162.146
18	10.7	0.364	0.78	30.2	166.494
19	10.8	0.367	0.788	30.8	170.874
20	10.9	0.37	0.795	31.3	175.325
21	11	0.374	0.802	31.8	179.889
22	11.1	0.377	0.81	32.3	184.607
23	11.2	0.381	0.817	32.9	189.52
24	11.3	0.384	0.824	33.5	194.667
25	11.4	0.387	0.832	34.1	200.087
26	11.5	0.391	0.839	34.8	205.819
27	11.6	0.394	0.846	35.5	211.9
28	11.7	0.398	0.853	36.3	218.371
29	11.8	0.401	0.861	37.2	226.001
30	11.9	0.404	0.868	38.5	235.476
31	12	0.408	0.875	39.7	245.083
32	12.1	0.411	0.883	40.9	254.821
33	12.2	0.415	0.89	42.2	264.691
34	12.3	0.418	0.897	43.4	274.691
35	12.4	0.421	0.904	44.6	284.823
36	12.5	0.425	0.912	45.9	295.086
37	12.6	0.428	0.919	47.1	305.48
38	12.7	0.432	0.926	48.4	316.004
39	12.8	0.435	0.934	49.6	326.66
40	12.9	0.438	0.941	50.8	337.445
41	13	0.442	0.948	52.1	348.361

Figure 27. Speed vs. Resistance curve

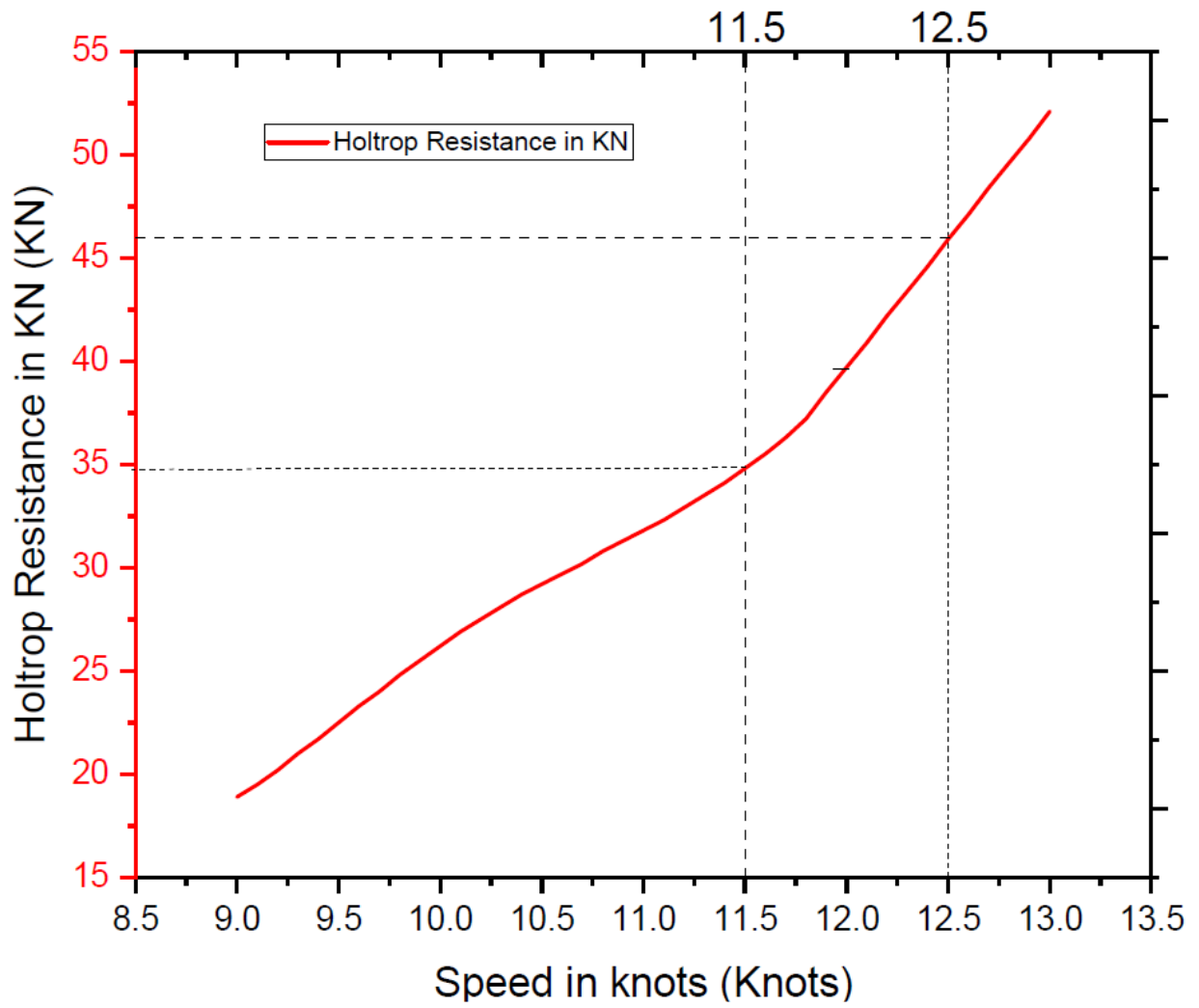

8.1 Holtrop effective power Calculation

Table 10. Holtrop effective power requirement for cruising speed

Calculation of Holtrop Effective Power of 24 Motor Yacht (SERENE)				
Ship SPEED (knot)	Total Resistance, R_T (kN)		Holtrop Effective Power, P_E	
	Without Margin	with 10% Margin (See Note)	(kW)	(HP)
9.00	19.82	21.80	100.9	135.31
9.50	24.57	27.03	132.1	177.06
10.00	28.27	31.10	160.0	214.45
10.50	30.09	33.10	178.8	239.66
11.00	31.63	34.79	196.9	263.93
11.50	34.12	37.53	222.0	297.70
12.00	38.21	42.03	259.5	347.82
12.50	44.63	49.09	315.7	423.18
13.00	54.35	59.79	399.8	535.96

Note: Margin for Wind, Wave & others.

Note:

- Speed 1 Knot = 0.5144 m/s, for 11.5 Knots = 5.9156 m/s
- Effective Power $P_E = R_T * V * 0.5144$ (KW), Where V = Speed in knots
- 1 KW = 1.341 HP

8.2 Engine model and propeller shaft power

Speed	Speed	P_E	Proposed Engine and Propeller shaft power	Total power and quantity
Cruising Speed	11.5 Knots	222.0 KW	Inboard Performance System IPS600 series, Propshaft power 307 KW	2 no = 1 port + 1 stbd.
Maximum Speed	12.5 Knots	315.7 KW		Total =614 KW@3500 rpm

8.2.1 Inboard performance system IPS 600 series

VOLVO PENTA **INBOARD PERFORMANCE SYSTEM**

IPS 350/400/450/500/600

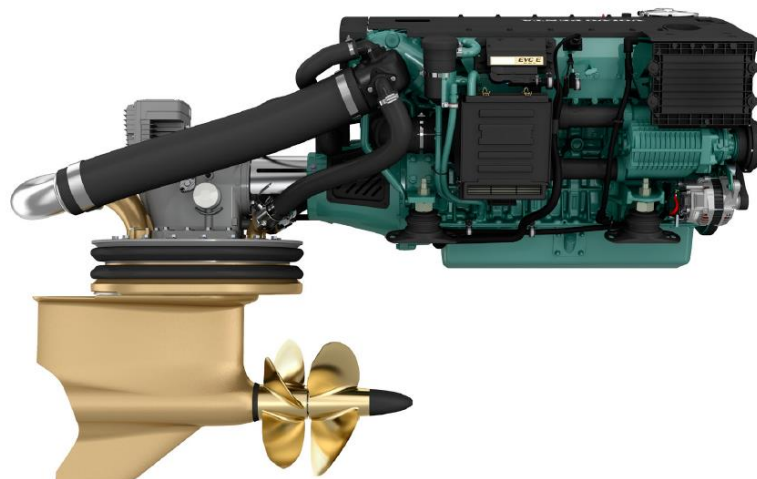

Figure 28. VOLVO PENTA IPS 600 series technical data

General Data

System designation	IPS350	IPS400	IPS450	IPS500	IPS600
Engine displacement, l (in ³)	3.7 (224)	3.7 (224)	5.5 (336)	5.5 (336)	5.5 (336)
Configuration	in-line 4	in-line 4	in-line 6	in-line 6	in-line 6
Crankshaft power, kW (hp) @ 3500 rpm	191 (260)	221 (300)	243 (330)	272 (370)	320 (435)
Propshaft power, kW (hp) @ 3500 rpm	182 (248)	212 (289)	230 (314)	259 (352)	307 (418)
Aspiration	Turbo, aftercooler, compressor		Turbo, aftercooler	Turbo, aftercooler, compressor	
Rating	R5**	R5**	R4*	R5**	R5**
Package weight, kg (lb)	780 (1720)	780 (1720)	863 (1903)	887 (1955)	901 (1986)
Propeller series	T2-T10, TS3-TS6	T2-T10, TS3-TS6	T2-T10, TS3-TS6	T2-T10, TS3-TS6	T2-T10, TS3-TS6
Voltage	12 V	12 V	12V or 24V	12V or 24V	12V or 24V
Emission compliance	IMO NOx, EU RCD Stage II, US EPA Tier 3				
Application	Twin/multiple engine installation in planing hulls				
Speed range	17 to 45 knots				

Driveshaft Compact (standard), jackshaft as option

Technical data according to ISO 8665. With fuel having an LHV of 42700 kJ/kg and density of 840 g/liter at 15°C (60°F). Merchant fuel may differ from this specification which will influence engine power output and fuel consumption.

*RATING 4. For light planing craft in commercial operation

**RATING 5. For pleasure craft applications, and can be used for high speed planing crafts in commercial applications

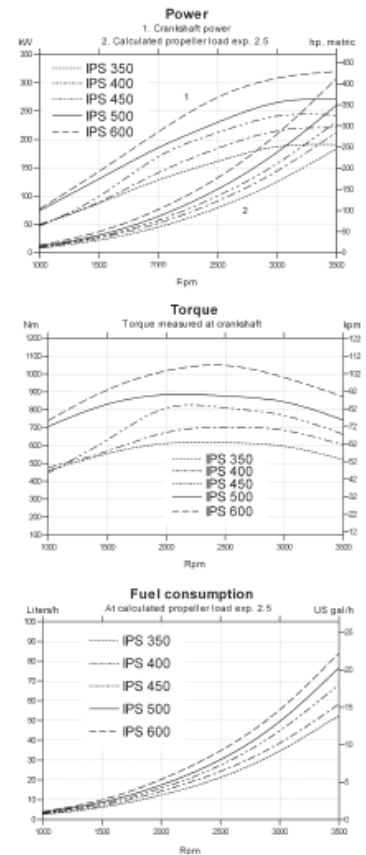

8.3 Fuel consumption and cruising distance

Figure 29. Fuel Consumption curve

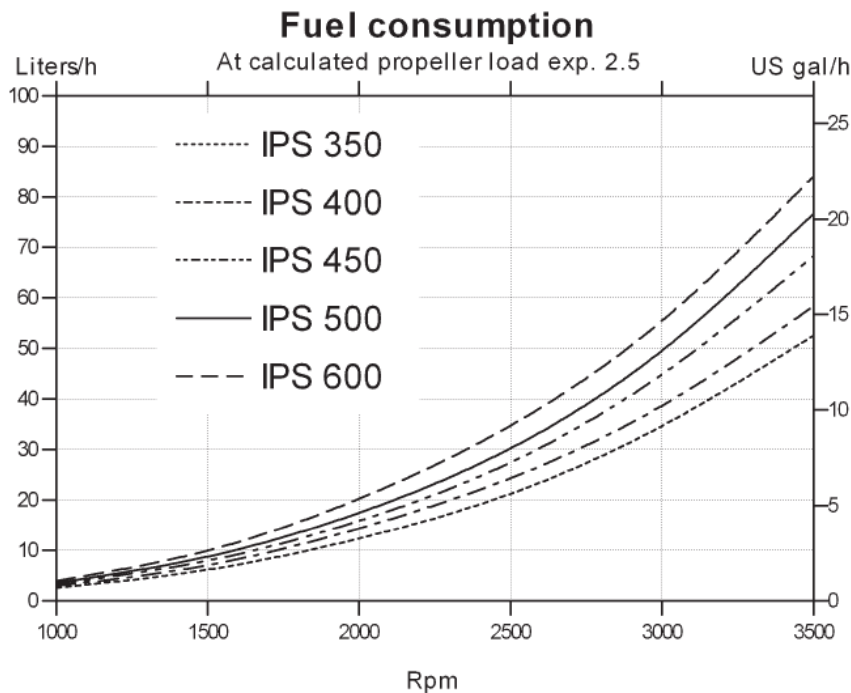

From Volvo Penta IPS 600 series catalogue following fuel consumption has been considered for our cruising distance calculation.

SERENE has been designed with

- A cruising speed of 11.5 Knots
and
- Maximum speed 12.5 Knots.

For selected IPS600 series with an RPM 3500 Fuel consumption will be 85 Litres per hour. SERENE has been designed with two diesel fuel oil tanks with 3600 L capacity each.

At full load condition with 3500 rpm at an speed of 11.5 Knots SERENE can voyage $3600 \times 2 \text{ L} / 85 = 84.7$ Hours. And within this period at a speed of 11.5 Knots cruising distance will be $= 11.5 * 84.7 = 974.05$ Nautical miles.

98%- 100% Fuel loading condition voyage from Genoa to Malta can reach within 1.5 days @11.5 Knots.

Figure 30. Sea route from Geona to Malta 711 Nautical miles

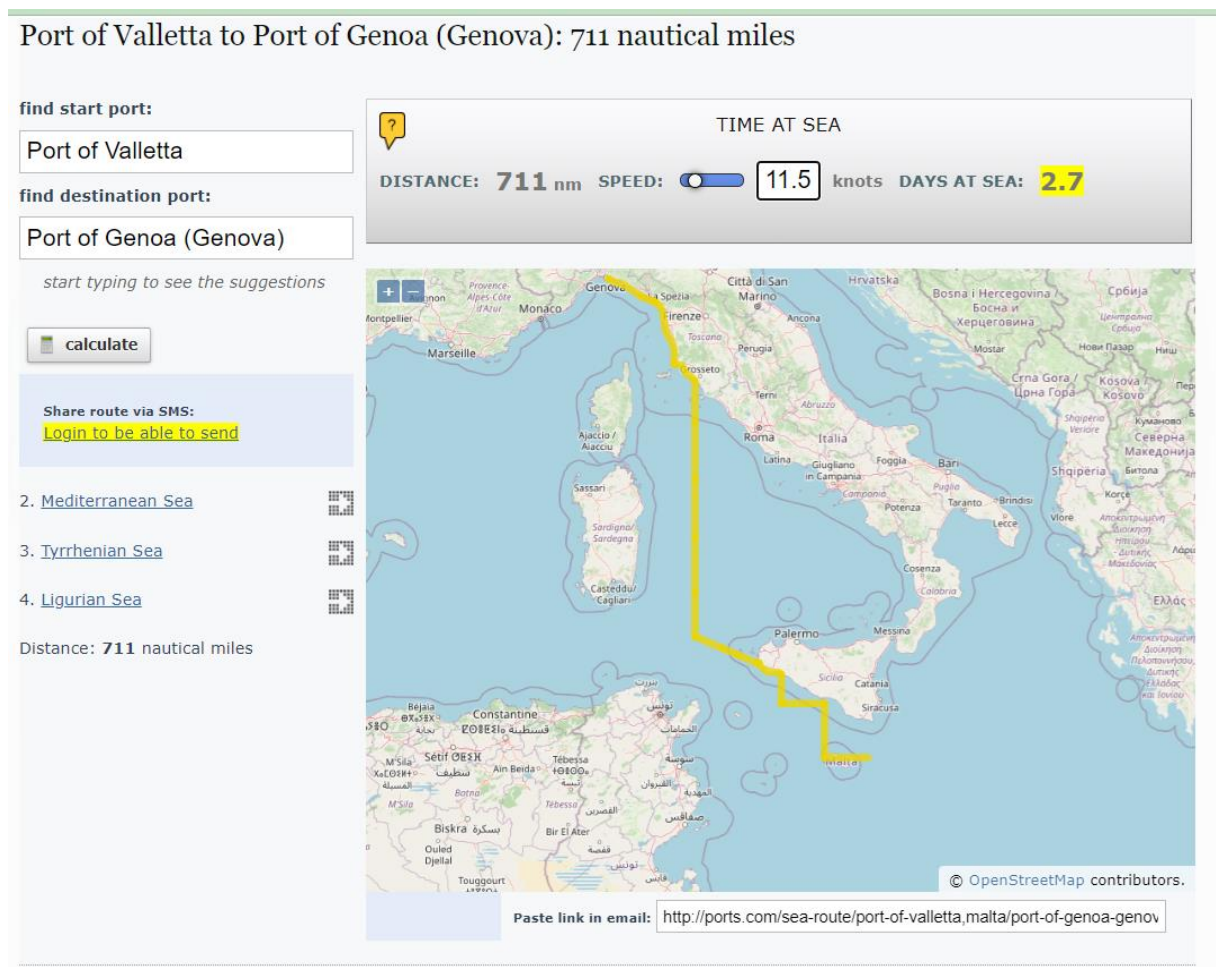

9. Bilge and Fire fighting system

9.1 Fire Fighting System

Since the Yacht's length is within 24 meters there is no specific requirement for a firefighting system.

The following portable CO₂ (9L/6 L) Bottle has been provided on board.

- Engine room – 3 No (9L)
- Crew area – 1 No – 6L
- Owner cabin and corridor – 1 No 6L
- Upper deck common area – 2 No 6L
- Bridge deck – 1 No 6 L

9.2 Bilge System

For the Bilge system schematic diagram has been drawn based on the following requirement from

Diameter of Main Bilge line, $D_M = 1.5 * [\sqrt{L(B+D)}] + 25 \text{ mm}$ (Inner Diameter)

Where, L = Length between perpendicular = 23.36 m

B = Breadth of yacht = 6.95 m

D = Depth of yacht = 3.65 m

$D_M = 48.60 \text{ mm}$ Inner diameter \geq DN 50 Sch40, (OD 60.3mm, WT 3.91mm)

Diameter of Branch Bilge line, $D_b = 2.16 * [\sqrt{C(B+D)}] + 25 \text{ mm}$ (Inner Diameter)

Where, C = Length of compartment = 5.75 m

B = Breadth of yacht = 6.95 m









D = Depth of yacht = 3.65 m

$D_b = 41.86 \text{ mm}$ Inner diameter \geq DN 40 Sch40, (OD 48.3 mm, WT 3.68 mm)

Bilge Pump Capacity,

$$Q = 0.00575 \times D_M^2 = 0.00575 \times (48.60)^2 = 13.58 \text{ m}^3/\text{hr}$$

9.3 Bilge system schematic drawing

-  COMPOUND GAUGE
-  PRESSURE GAUGE
-  BILGE PUMP 14 M3/HR
-  BILGE SUCTION
-  STRAINER
-  PASSING THROUGH BHD/FLOOR FLANGE BOTH SIDE
-  OVER BOARD
-  SDNR - SCREW DOWN NON RETURN VALVE

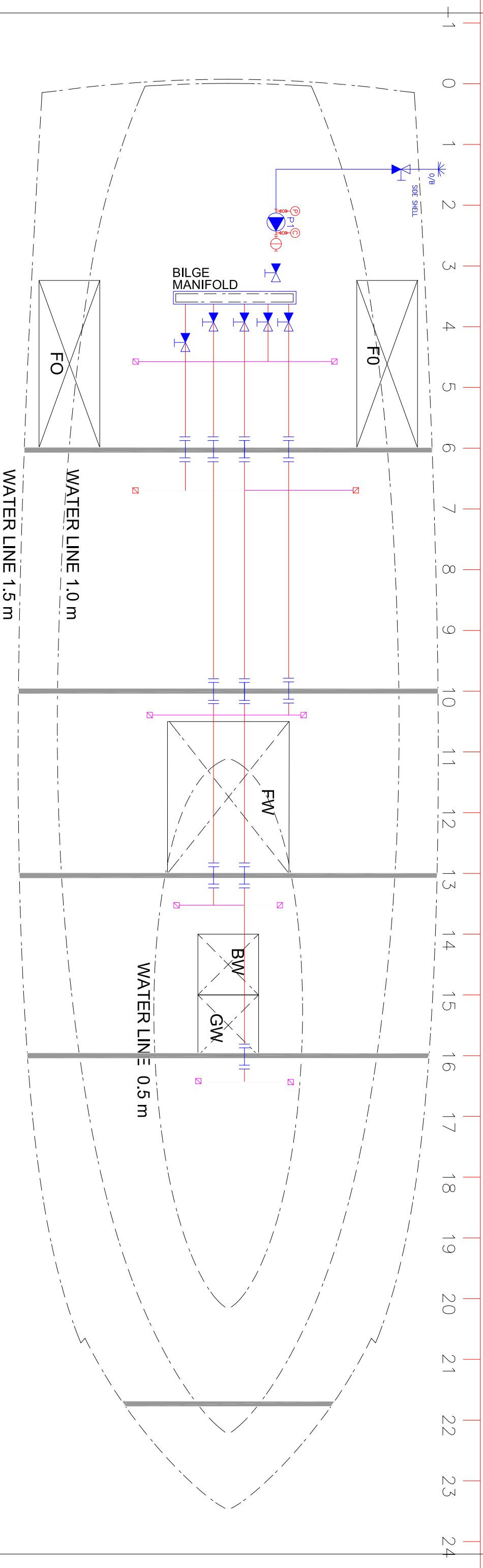

BILGE SYSTEM

10. Conclusion

In the future study more detailed hull construction drawings to be developed together with 3d interior and exterior modeling. In addition, resistance, and propulsive power are also to be calculated for arrival and voyage conditions.